

# *VetScan* **VSpro**

## VetScan VSpro Specialty Analyzer Operator's Manual

---

**For Veterinary Use Only**

**Abaxis Customer Service and  
Technical Support: 1-800-822-2947  
Available 24 hours a day, 7 days a week**

**November 2011**

**Abaxis and VetScan  
are registered trademarks of Abaxis.**

**©2011, Abaxis, Inc.  
Union City, CA  
94587**

---

# Table of Contents

<b>Section 1: General Information .....</b>	<b>1-1</b>
1.1 Intended Use .....	1-1
1.2 Introduction .....	1-1
1.3 Basic Operating Principles .....	1-2
1.4 Features of the VetScan <i>VSpro</i> Specialty Analyzer .....	1-2
1.5 Abaxis Technical Support .....	1-2
1.6 Symbols Used in Labeling .....	1-3
1.7 User Information and Precautions .....	1-4
<b>Section 2: Setup and Analyzer Description....</b>	<b>2-1</b>
2.1 Unpacking .....	2-1
2.2 Main Components .....	2-2
2.3 Physical & Environmental Specifications .....	2-3
2.4 Setup .....	2-4
2.5 Home Screen .....	2-5
2.6 Help Screens .....	2-5
<b>Section 3: Configuring the Analyzer .....</b>	<b>3-1</b>
3.1 Settings Menu .....	3-1
3.2 Changing the Time .....	3-2
3.3 Changing the Date .....	3-2
3.4 Changing the Date Format .....	3-3
3.5 Updating the Software .....	3-3
3.6 Changing the Language .....	3-4
3.7 Copying Data from the Analyzer .....	3-4
3.8 Connecting an External Keyboard .....	3-4
<b>Section 4: Memory Database .....</b>	<b>4-1</b>
4.1 Overview .....	4-1
4.2 Viewing Archived Test Results .....	4-1
4.3 Performing a Database Search .....	4-2
<b>Section 5: Maintenance and Support .....</b>	<b>5-1</b>
5.1 Routine Maintenance .....	5-1
5.2 Cleaning the Air Filter .....	5-2
5.3 Abaxis Technical Support .....	5-3
<b>Section 6: Troubleshooting .....</b>	<b>6-1</b>
6.1 Abaxis Technical Support .....	6-1
6.2 Advisory Messages .....	6-2
6.3 Problems That Give No Advisory Message .....	6-4

<b>Section 7: Collecting Blood Samples .....</b>	<b>7-1</b>
7.1 Precautions Before Blood Sample Collection.....	7-1
7.2 Collecting Blood Samples.....	7-1
7.3 Sample Tube Fill Order.....	7-2
7.4 Handling Blood Samples.....	7-2
7.5 General Requirements.....	7-2
<b>Section 8: VSpro PT/aPTT Combination Test .....</b>	<b>8-1</b>
8.1 Introduction to PT/aPTT Testing .....	8-1
8.2 PT/aPTT Combination Test Specifications.....	8-4
8.3 PT/aPTT Combination Test Sample Preparation.....	8-5
8.4 PT/aPTT Combination Test Procedure .....	8-5
8.5 Test Performance .....	8-9
8.6 Limitations .....	8-9
<b>Section 9: VSpro Fibrinogen Test.....</b>	<b>9-1</b>
9.1 Introduction to Fibrinogen Testing .....	9-1
9.2 Fibrinogen Test Specifications.....	9-5
9.3 Customizing Fibrinogen Test Settings .....	9-6
9.4 Calibrating the VSpro Analyzer for Fibrinogen Testing .....	9-6
9.5 Fibrinogen Calibration Procedure .....	9-8
9.6 Preparing Fibrinogen Test Samples .....	9-13
9.7 Fibrinogen Test Procedure .....	9-14
9.8 Test Performance .....	9-17
9.9 Limitations .....	9-18
<b>Index.....</b>	<b>I-1</b>

## 1.1 Intended Use

The VetScan VSpro Specialty Analyzer provides quantitative in-vitro determination of:

- Fibrinogen
- PT (prothrombin time)
- aPPT (activated partial thromboplastin time)

**CAUTION:** *If the VetScan VSpro Specialty Analyzer is used in any way other than described in this manual, the analyzer may not operate as intended, may produce inaccurate or no results, and may pose a safety hazard.*

**Note:** *Use only VetScan VSpro PT/aPTT Combination Test and Fibrinogen Test cartridges with the VetScan VSpro Specialty Analyzer.*

## 1.2 Introduction

The VetScan VSpro is a compact, fully automated point-of-care analyzer designed for rapid specialty testing in veterinary clinics. The VetScan VSpro analyzes citrated samples in a single-use disposable test cartridge.

The VetScan VSpro contains microprocessors and LED optical elements to control all testing and analytical functionalities. The operator controls the analyzer functions through a 5.6-inch color touchscreen. An open slot in the front of the analyzer allows the insertion of the cartridge, and guides the test cartridge into place for analysis.

The VetScan VSpro test cartridges are a clear plastic strip about 3" x 1" in size. Each cartridge has an optical detection window and is preloaded with dry reagents specific to the tests. All blood reactions occur within the test cartridge.

Test results are displayed on screen, and automatically stored in memory for later retrieval. The results can also be printed to an optional printer via the USB printer port. An external keyboard can also be connected to the USB keyboard port if desired.

### **1.3 Basic Operating Principles**

The VetScan *VSpro* Specialty Analyzer enables veterinarians to perform in-clinic specialty testing using disposable cartridges.

The VetScan *VSpro*'s operation is based on light absorption. Blood sample added to the VetScan *VSpro* test cartridge flows through microchannels in the cartridge where it reacts with reagents that initiate the reaction. The microfluidic cartridge design contains reaction chambers. Light passing through the optical detection window on the cartridge is absorbed by the sample in the channels. By measuring how much light is absorbed, the analyzer calculates the test results, which are displayed on screen and stored in the analyzer's database.

### **1.4 Features of the VetScan *VSpro* Specialty Analyzer**

- Large, easy-to-use touchscreen controls
- Small sample size (< 100 µl)
- Fast and accurate point-of-care results
- Simple and user-friendly operation
- Continuous internal self-test monitoring during operation
- Small footprint
- Up to 1000 detailed test results can be stored and retrieved
- Allows for Patient and Sample ID input

### **1.5 Abaxis Technical Support**

Abaxis Technical Support can answer your questions regarding the operation of the VetScan *VSpro* Specialty Analyzer. Call Abaxis Technical Support, 24 hours a day, 7 days a week, at 1-800-822-2947.

## 1.6 Symbols Used in Labeling

The following symbols are found on the VetScan VS*pro* Specialty Analyzer and/or the power supply:



Caution, risk of danger (see the accompanying warning text)



Caution, risk of electric shock



Alternating Current



Direct Current



USB Connection

## 1.7 User Information and Precautions

Please read the instructions in this Operator's Manual carefully before using the VetScan VS*pro*, and follow all instructions and warnings.

**WARNING:** *Electrical equipment may be hazardous if misused. Do not attempt to open or disassemble the analyzer. Doing so will void the warranty, and present a risk of electric shock.*

**WARNING:** *Do not use the VetScan VS*pro* in or near water or wet locations to reduce the risk of electric shock. Protect the analyzer from dampness or wet weather such as rain or snow.*

- If the VetScan VS*pro* is used in a manner not specified by the manufacturer, the protection provided by the analyzer may be impaired.
- Do not use the VetScan VS*pro* if it appears to be damaged. Disconnect the power and contact Abaxis Technical Support.
- Use only the VetScan VS*pro* power supply. The use of any other power supply will damage the analyzer and void the warranty.
- Do not expose the VetScan VS*pro* to extreme temperatures: below 15 °C (59 °F) and above 30 °C (86 °F).
- The power supply must be connected to a main power outlet that is grounded and of a quality normally found in hospitals, or in domestic or commercial environments.
- Do not use the VetScan VS*pro* in a manner not specified by the manufacturer.
- When the VetScan VS*pro* is not in use, it should be powered off.
- Do not drop the VetScan VS*pro*. If it has been accidentally dropped, contact Abaxis Technical Support immediately. Do not conduct further tests with the VetScan VS*pro* until it has been serviced by an authorized service provider.
- Do not attempt to repair the VetScan VS*pro*. The analyzer contains no user-serviceable parts. If service is needed, contact Abaxis Technical Support.
- Do not use excessive force or sharp objects on the VetScan VS*pro*'s sensitive LCD touchscreen.
- Do not force a test cartridge into the cartridge slot. The cartridge should slide in easily.
- Do not use non-VetScan VS*pro* test cartridges with the VetScan VS*pro*. A non-VetScan VS*pro* test cartridge will not operate in the analyzer, and will cause an advisory message.



# Setup and Analyzer Description

## 2.1 Unpacking

1. Remove the VetScan *VSpro* Specialty Analyzer from the shipping carton. Place the analyzer on a level surface relatively free of animal hair, dust and other contaminants. Do not place near a window or heat source.
2. Make sure you received the following components:
  - VetScan *VSpro* Specialty Analyzer
  - Power supply with cord
  - Power cord
  - VetScan *VSpro* Specialty Analyzer Operator's Manual and Quick Reference Guide
3. To start the warranty period, complete the warranty information at installation or by visiting [www.abaxis.com/warranty](http://www.abaxis.com/warranty) within 10 days of installation. Customers are placed on the customer mailing list to receive information pertaining to the VetScan *VSpro* and ancillary products, such as software updates.

## 2.2 Main Components

The VetScan VS*pro* system consists of a portable analyzer and a disposable single-use test cartridge. A new VetScan VS*pro* test cartridge is required for each analysis.



### Component Overview

<b>Touchscreen</b>	Point of interaction between the operator and the analyzer.
<b>Cartridge slot</b>	Point of insertion of VetScan VS <i>pro</i> Test Cartridge into the analyzer.
<b>Power button</b>	Powers the analyzer on and off.
<b>Power supply connector</b>	Connects the analyzer's 12V DC power supply.
<b>USB printer port</b>	For connecting an optional printer, updating software, and copying data.
<b>USB keyboard port</b>	For connecting an optional external keyboard.
<b>LAN port</b>	For connecting to external data management systems.

## 2.3 Physical & Environmental Specifications

<b>Analyzer dimensions</b>	Height:	31 cm	12.2 in
	Width:	15 cm	5.9 in
	Depth:	17 cm	6.7 in
<b>Weight</b>	Analyzer:	2.5 kg	5.5 lbs
	Power Adapter:	0.5 kg	1.1 lbs
<b>Mode of operation</b>	Continuous		
<b>Protection against ingress of fluid</b>	Ordinary equipment (IPX0)		
<b>Ambient operating temperature</b>	15–30 °C (59–86 °F), indoor use only		
<b>Relative humidity</b>	0%–80% non-condensing		
<b>Maximum altitude</b>	2000 m (6562 ft)		
<b>Pollution degree</b>	2		
<b><i>IMPORTANT: The analyzer must be placed at least 6 inches (15 cm) from the nearest object.</i></b>			
<b>Power requirements (power supply)</b>	Input:	100–240 volts AC, 1.5 A, 50–60 Hz	
	Output:	12 volts DC, 6.7 A	
<b>Power requirements (analyzer)</b>	Input:	12 volts DC, 2.7 A	
	Power consumption:	32.4 Watts	
<b>Transient over-voltage</b>	Category II of IEC 60364-4-443		
<b>Analyzer input connections</b>	12 volts DC		
<b>Analyzer input and output connections</b>	LAN, USB 2.0		
<p>The detachable power supply cord set and appliance inlet of the external power supply are considered to be the disconnecting device.</p> <p>The USB interface connector of the VetScan VSpro Analyzer must only be connected to SELV circuits.</p> <p>The LAN connector must only be connected to 10Base-T/100Base-TX circuits. External computing devices connected to the USB and LAN interface connectors have to comply with the standard UL60950 for US and Canada, and IEC60950 for other countries.</p>			

## 2.4 Setup

1. Check that the VetScan VSpro analyzer is:
  - On a level surface
  - Located in an ambient operating temperature (15–30 °C, 59–86 °F)
  - Not placed in a window, in direct sunlight, or near a heat source
  - On a bench, free of vibration and sudden jolts
  - Free of animal hair, dust, and other contaminants
  - At least 15 cm (6 inches) from the wall to the power connection and USB ports
2. Plug the power jack into the analyzer, and plug the detachable power supply cord into the power supply and into a grounded electric outlet.

**Note:** Use only the VetScan VSpro power supply. Any other power supply will damage the analyzer and void the warranty.

3. Press the Power button to turn on the analyzer. The system displays the Abaxis logo, then begins a Self-Test sequence, and displays the **Home** screen when ready for analysis.

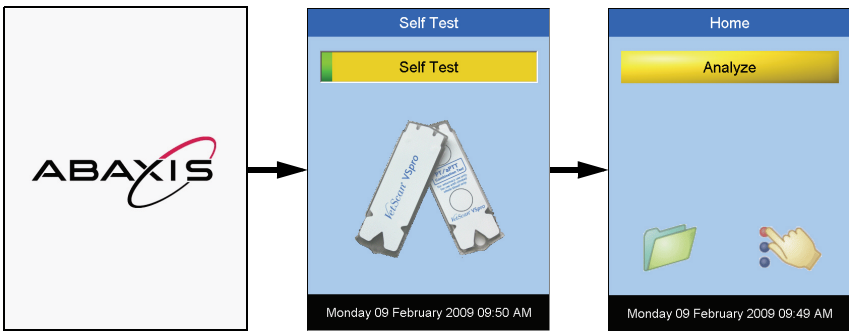

## 2.5 Home Screen

1. This is the main menu screen. There are three touch buttons, each of which leads to an operation menu.
  - **Analyze** Menu (yellow bar) – touch the button to start a test.
  - **Settings** Menu (hand icon) – touch the button to initiate the configuration of the analyzer.
  - **Memory** Menu (folder icon) – touch the button to access the results database for data search and retrieval.

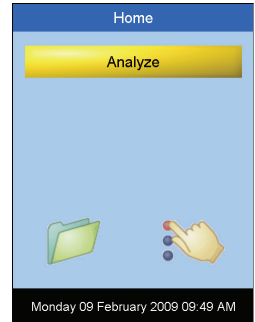

2. At this point, the analyzer is ready for testing.
3. Check the date and time displayed to ensure they are correct. Refer to Section 3, “Configuring the Analyzer” for directions to make the necessary adjustments.

**Note:** When the analyzer is on, pressing the Power button turns it off.

## 2.6 Help Screens

Many of the analyzer’s screens include a **Help** button that displays additional information on using the screens, menus, and commands.

For example, the **Help** button in the cartridge code screen displays help for entering the cartridge code:

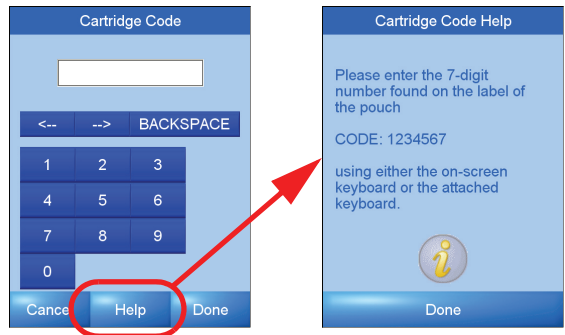



# Configuring the Analyzer

The VetScan VSpro Specialty Analyzer can be configured through the **Settings** menu, accessible through the Settings icon in the **Home** screen.

**IMPORTANT:** *Do not use excessive force or sharp objects on the analyzer's sensitive LCD touchscreen.*

## 3.1 Settings Menu

1. In the **Home** screen, touch the Settings icon.

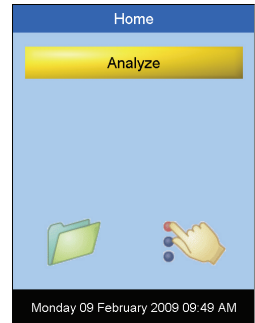

2. The **Settings** menu opens. Use this menu for the following:

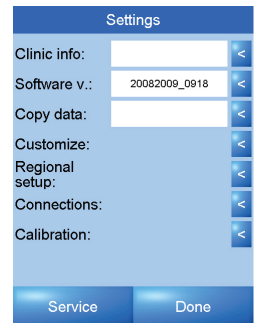

- Adjusting the date, time, US/Europe format, or language
- Performing calibrations or software updates
- Copying data



3. Touch **Done** to return to the **Home** screen.

**Note:** *The **Service** button is for use only by an authorized service provider to access the analyzer's internal system functions, and requires a password.*

## 3.2 Changing the Time

1. From the **Settings** menu, touch the  button to the right of **Regional setup**.
2. Touch the  button to the right of **Time**.

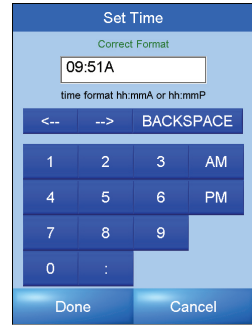
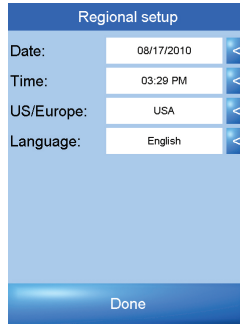

The **Set Time** screen opens, with an on-screen keyboard.

3. Type in the time using the format shown below the text box.
4. Touch **Done** to return to the **Settings** menu.



**Note:** A red message appears under the text box until a complete time entry in the correct format is made. When the entry is complete and in the correct format, the message changes to green.

## 3.3 Changing the Date

1. From the **Settings** menu, touch the  button to the right of **Regional setup**.
2. Touch the  button to the right of **Date**.

The **Set Date** screen opens, with an on-screen keyboard.

3. Type in the date using the format shown below the text box.
4. Touch **Done** to return to the **Settings** menu.

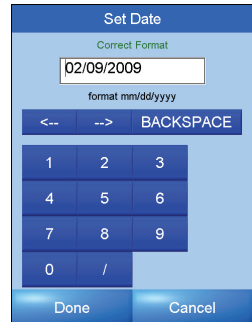
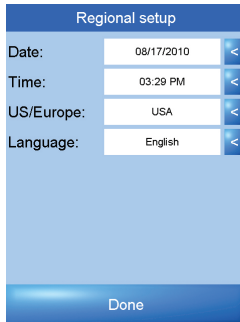



**Note:** A red message appears under the text box until a complete date entry in the correct format is made. When the entry is complete and in the correct format, the message changes to green.

**Note:** Touch **Cancel** to undo any changes and return to the **Settings** menu.



### 3.4 Changing the Date Format

1. From the **Settings** menu, touch the  button to the right of **Regional setup**.
2. Touch the button to the right of **USA** or **Europe** to select a date format.

The current selection is indicated by .

3. Touch **Done** to accept the change.



### 3.5 Updating the Software

A software update requires you to obtain from Abaxis a USB memory stick containing an installer for the new software.

The analyzer's current software version is shown in the **Settings** screen.

1. Unplug any device that may be plugged into the USB printer port on the back of the analyzer.
2. Insert the installer USB memory stick into the printer port.
3. Touch the  button to the right of **Software v.**

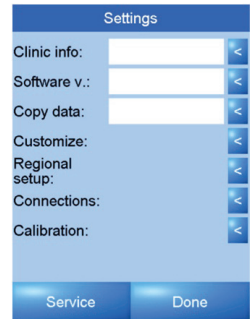

The **Software** screen opens and shows the current software version.

4. Touch **Upgrade** to perform the upgrade to the new version.

**Note:** *While updating the software, do not power off the analyzer. If power is lost during the software update, contact Abaxis Technical Support.*

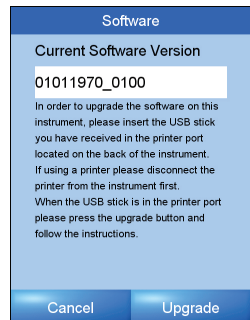

### 3.6 Changing the Language

**Note:** Only English is currently available for all VetScan VSpro Specialty Analyzers.

1. From the **Settings** menu, touch the  button to the right of **Regional setup**.
2. Touch **Language**.

The **Language** screen opens. The selected language is indicated by the  button.

3. Touch the button to select a language. The button then turns green.
4. Touch **Done** to accept the change, or **Cancel** to exit without change.



### 3.7 Copying Data from the Analyzer

All results stored in the analyzer can be copied to a USB memory stick.

1. Unplug any device that may be plugged into the USB printer port on the back of the analyzer.
2. Insert a USB memory stick into the printer port on the back of the analyzer, and wait 10 seconds.
3. From the **Settings** menu, touch the  button to the right of **Copy data**.

Data automatically begins copying from the analyzer to the memory stick, and takes a few seconds.

4. The copying is done as indicated by **Data copied** in the **Settings** menu.



### 3.8 Connecting an External Keyboard

1. Turn off the VetScan VSpro by pressing the Power button on the front of the analyzer.
2. Connect the keyboard to the analyzer using the USB keyboard port on the back of the analyzer.
3. Turn on the VetScan VSpro by pressing the Power button.

**Note:** The analyzer can only use a keyboard approved by the manufacturer as compatible with the VetScan VSpro.

### 4.1 Overview

- Up to 1000 test results are automatically stored in the memory folder.
- The files in the database are sorted by date with the most recent first.
- Each file is stored with Patient ID, Sample ID, Test Date and Time, and test results.
- A built-in search function can retrieve test results by Patient or Sample ID, or by Date.
- Test results can be printed if an optional printer is connected.

**IMPORTANT:** *Do not use excessive force or sharp objects on the analyzer's sensitive LCD touchscreen.*

### 4.2 Viewing Archived Test Results

1. Touch the **Memory** folder from the **Home** screen to access the database.

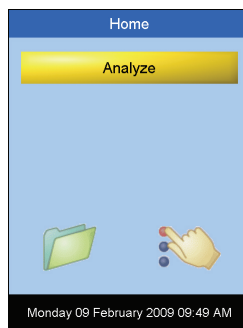

2. Touch the ▲ and ▼ buttons to scroll through the files in the database.

The screenshot shows the Memory screen with a blue header labeled 'Memory'. Below the header is a table with the following data:

Date / Time	Patient ID	Sample ID	Test type
02/09/2009 09:58 AM	Boxer 45		PT/aPTT combo
02/02/2009 10:10 AM	Boxer 45		PT/aPTT combo
01/07/2009 03:00 AM	Boxer 45		PT/aPTT combo
			opk 43
			opk42
			sample2

At the bottom of the screen, there are three buttons: Search, Resend, and Done. Above the Search button are two navigation arrows: an upward-pointing triangle (▲) and a downward-pointing triangle (▼).

3. Touch a file on the screen to review the test results. The test result is retrieved in the same format as it was originally obtained. If a printer is connected to the analyzer the test result can be printed by touching the **Print** button.

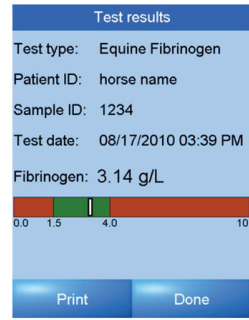
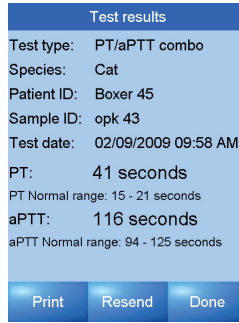



4. Touch the **Done** button to return to the **Memory** screen.
5. Touch the **Done** button again to return to the **Home** screen.

### 4.3 Performing a Database Search

#### Search by Patient ID

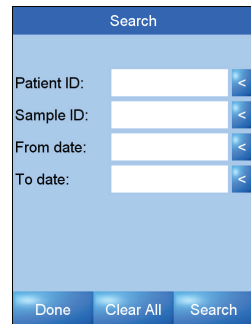
1. Touch the **Memory** folder from the **Home** screen, and then the **Search** button from the **Memory** screen to access the **Search** menu.



2. Touch the  button to the right of the **Patient ID** to perform the search by Patient ID.

An on-screen alphabetic or numeric keyboard opens. Touch the **ABC** or **123** button to switch between the keyboards.

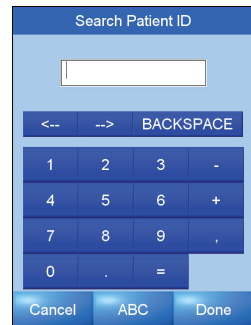

3. Type in the Patient ID, then touch **Done** to register the search entry, or **Cancel** to clear the entry and return to the **Search** menu.

4. Touch the **Search** button from the **Search** screen to begin the search, or **Clear All** to restart the search process.
5. Use the ▲ and ▼ buttons to scroll through the search results.

Search results		
Date / Time	Patient ID	Test type
02/09/2009 09:58 AM	Boxer 45	PT/aPTT combo
		opk 43
02/02/2009 10:10 AM	Boxer 45	PT/aPTT combo
		opk42
01/07/2009 03:00 AM	Boxer 45	PT/aPTT combo
		sample2

▲ ▼

Show all   Resend   New search

6. Touch the desired file to view the result information, or touch **Done** and then **New Search** to return to the **Search** menu to refine the search. To show all test results, touch the **Show all** button.

Test results	
Test type:	PT/aPTT combo
Species:	Cat
Patient ID:	Boxer 45
Sample ID:	opk 43
Test date:	02/09/2009 09:58 AM
PT:	41 seconds
PT Normal range:	15 - 21 seconds
aPTT:	116 seconds
aPTT Normal range:	94 - 125 seconds

Print   Resend   Done

Test results	
Test type:	Equine Fibrinogen
Patient ID:	horse name
Sample ID:	1234
Test date:	08/17/2010 03:39 PM
Fibrinogen:	3.14 g/L

0.0   1.5   4.0   10

Print   Done

7. Touch **Done** to return to the **Search Results** screen to view another search result.
8. Touch **Done** again to return to the **Home** screen.

### Search by Sample ID

1. Touch the **Memory** folder from the **Home** screen, and then the **Search** button from the **Memory** screen to access the **Search** menu.



Search	
Patient ID:	<input type="text"/>
Sample ID:	<input type="text"/>
From date:	<input type="text"/>
To date:	<input type="text"/>

Done   Clear All   Search

- Touch the  button to the right of **Sample ID** to perform the search by Sample ID.

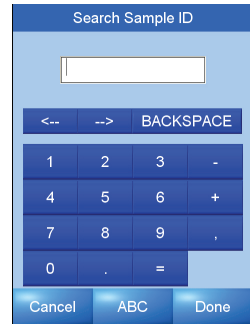
An on-screen alphabetic or numeric keyboard opens. Touch the **ABC** or **123** button to switch between the keyboards.



- Type in the sample ID, and then touch the **Done** button to register the search entry, or the **Cancel** button to clear the entry and return to the **Search** menu.
- Touch the **Search** button from the **Search** screen to begin the search, or the **Clear All** button to restart the search process.
- Use the  and  buttons to scroll through the search results.

Date / Time	Test type	Sample ID
02/09/2009 09:58 AM	PT/aPTT combo	opk 43
Boxer 45		opk 43
02/02/2009 10:10 AM	PT/aPTT combo	opk42
Boxer 45		opk42
01/07/2009 03:00 AM	PT/aPTT combo	sample2
Boxer 45		sample2

- Touch the desired file to view the result information, or touch **Done** and then **New Search** to return to the **Search** menu to refine the search. To show all test results, touch the **Show all** button.

Test results	
Test type:	PT/aPTT combo
Species:	Cat
Patient ID:	Boxer 45
Sample ID:	opk 43
Test date:	02/09/2009 09:58 AM
PT:	41 seconds
PT Normal range:	15 - 21 seconds
aPTT:	116 seconds
aPTT Normal range:	94 - 125 seconds

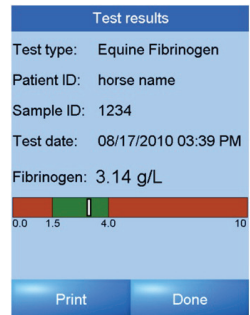

- Touch **Done** to return to the **Search Results** screen to view another search result.
- Touch **Done** again to return to the **Home** screen.

## Search by Date

1. Touch the **Memory** folder from the **Home** screen, and then the **Search** button from the **Memory** screen to access the **Search** menu.

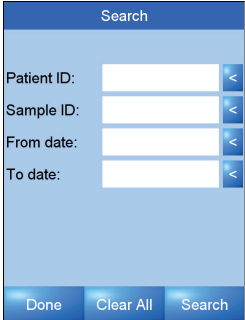

The screenshot shows the 'Search' menu with four input fields: 'Patient ID:', 'Sample ID:', 'From date:', and 'To date:'. Each field has a small blue button with a left-pointing arrow to its right. At the bottom of the screen are three buttons: 'Done', 'Clear All', and 'Search'.

2. Touch the  button to the right of **From date** to search by start date.

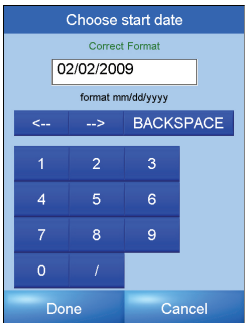

The screenshot shows the 'Choose start date' dialog. It features a text input field containing '02/02/2009' with the label 'Correct Format' above it. Below the field is the text 'format mm/dd/yyyy'. There are navigation buttons '<--', '-->', and 'BACKSPACE'. A numeric keypad is displayed with digits 1-9, 0, and a slash '/' key. At the bottom are 'Done' and 'Cancel' buttons.

3. Type in the start date using the format shown on the screen. Touch **Done** to register the search entry, or **Cancel** to clear the entry and return to the **Search** menu.
4. Touch the **Search** button from the **Search** screen to begin the search, or the **Clear All** button to restart the search process.
5. To search the database by the end date, touch the  button to the right of **To date**.
6. Type in the end date using the format shown on the screen. Touch **Done** to register the search entry, or **Cancel** to clear the entry and return to the **Search** menu.

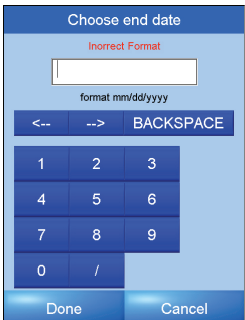

The screenshot shows the 'Choose end date' dialog. It features a text input field with the label 'Incorrect Format' above it. Below the field is the text 'format mm/dd/yyyy'. There are navigation buttons '<--', '-->', and 'BACKSPACE'. A numeric keypad is displayed with digits 1-9, 0, and a slash '/' key. At the bottom are 'Done' and 'Cancel' buttons.





### 5.1 Routine Maintenance

The VetScan VSpro requires minimal maintenance. For routine maintenance, it is strongly recommended to visually inspect the surface for cleanliness and damage on a regular basis.

**Note:** *Do not use the VetScan VSpro if it appears to be damaged. Disconnect the power, and contact Abaxis Technical Support at 1-800-822-2947.*

When performing routine maintenance pay special attention to the cartridge slot opening. Removal of dried blood, dirt or other foreign matters can be done by using a water-moistened cotton swab or a damp cloth. Ensure removal of residual water with a dry cotton swab or a dry cloth after each cleaning.

If a disinfectant is used make sure to wipe the analyzer thoroughly with a water-dampened cloth or cotton swab to remove any residual disinfectant.

**Note:** *For safety reasons make sure the analyzer is unplugged when it is cleaned.*

**CAUTION:** *Do not use solvents or strong cleaning solutions on the analyzer, as they may damage the analyzer's surface and the LCD touchscreen.*

**CAUTION:** *Do not spray or pour any detergents, solutions or other liquids directly onto the analyzer.*

**Note:** *Damage caused by non-recommended cleaning methods is not covered by the warranty.*

## 5.2 Cleaning the Air Filter

Clean the air filter in the back of the analyzer at least monthly, or as needed to ensure proper ventilation and temperature control of the analyzer. Check the filter frequently if the analyzer is in an environment with excessive dust or animal hair.

1. Turn the analyzer off by pressing and holding the Power button.
2. Remove the power cord from the back of the analyzer.
3. Unsnap the air filter cover on the back of the analyzer. You can use a small screwdriver or similar object to lift the cover out from the analyzer.

**Note:** *Do not loosen the screws that hold the air filter cage to the analyzer.*

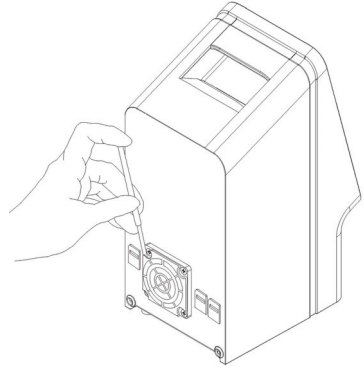

4. Lift off the air filter cover, then remove the air filter.

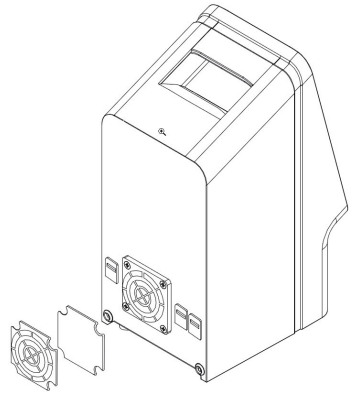

5. Wash the air filter with warm water to remove dust, animal hair, and any other debris.
6. Dry the air filter and place it back into the air filter cage.

**CAUTION:** *Make sure the air filter is completely dry before placing it back into the air filter cage.*

7. Snap the air filter cover back into place over the air filter.
8. Plug the power cord into the back of the analyzer.
9. Press the Power button. The analyzer then performs a Self-Test, and displays the **Home** screen when ready for analysis.

### 5.3 Abaxis Technical Support

During operation, the analyzer continuously monitors its internal hardware and software, and reports problems on the display screen as advisory messages (see the troubleshooting section). If for any reason the analyzer does not perform properly, and needs to be serviced, please contact Abaxis Technical Support, 24 hours a day, 7 days a week, at 1-800-822-2947.

**Note:** *The VetScan VSpro has no user-serviceable parts.*

**Note:** *The VetScan VSpro has an anti-tampering device. The warranty is voided if the analyzer is opened by the user or a non-authorized service provider.*

**Note:** *There is a battery on the computer board inside the analyzer for power backup. Replacement of this battery must be carried out by an authorized service provider.*



### **6.1 Abaxis Technical Support**

If the troubleshooting recommendations contained in this section do not correct the problem with the analyzer, record the advisory message and contact Abaxis Technical Support, 24 hours a day, 7 days a week, at 1-800-822-2947.

## 6.2 Advisory Messages

The analyzer screen displays advisory messages if problems occur. These messages include an internal code that will assist in diagnosing the problem. Follow the procedures in this section to determine the cause and solution of any problems the analyzer may be having.

#	Advisory message	Cause	Corrective action
2	No Blood Detected	Blood added too late or not enough blood added to cartridge sample well.	Repeat test with new cartridge and ensure enough blood is added to cartridge when prompted on screen.
7	Test Error	Possible faulty cartridge.	Repeat test with new cartridge.
8	Test Error	Not enough blood added to test cartridge or possible faulty cartridge.	Repeat test with new cartridge, and ensure enough blood is added to cartridge.
9	Test Error	Premature loading of sample.	Add sample when prompted. Repeat test with a new cartridge.
10	Internal Instrument Error	Electronics communication error.	Turn off and restart analyzer. If problem persists, contact Abaxis Technical Support.
12	Instrument Temperature Too Low	Ambient temperature too low.	Ensure room temperature is 15–30 °C (59–86 °F). If problem persists, contact Abaxis Technical Support.
13	Instrument Temperature Too High	Ambient temperature too high.	Ensure analyzer is cooled sufficiently and room temperature is 15–30 °C (59–86 °F).
14 15 16	Signal Error	Light detector signal too low.	Ensure cartridge slot is free of foreign objects. Repeat test with new cartridge. If problem persists, contact Abaxis Technical Support.
17 18 19	Signal Error	Light detector signal too high.	Ensure cartridge slot is free of foreign objects. Repeat test with new cartridge. If problem persists, contact Abaxis Technical Support.

#	Error message	Cause	Corrective action
20	No Cartridge Detected	Test cartridge removed prematurely.	Repeat test with new cartridge.
22 23	Signal Error	Light detector signal error.	Ensure cartridge slot is free of foreign objects. Repeat test with new cartridge. If problem persists, contact Abaxis Technical Support.
24	Bad LIS Communication	Analyzer cannot connect to LIS/PMS.	Check communication to LIS.
25	Test Error	Signal too weak. Poor blood sample or possibly faulty cartridge.	Repeat test with new cartridge.
26	Invalid Cartridge	Inserted cartridge not valid for use with this analyzer.	Ensure valid <i>VSpro</i> cartridge is used and analyzer software is current.
29	Invalid calibration code	Invalid calibration code.	Ensure calibration code is correct.
30	Wrong Code Length	Invalid cartridge code.	Ensure 7-digit cartridge code is correct.
31	Checksum Error	Invalid cartridge code.	Ensure 7-digit cartridge code is correct.
32	Wrong Format Error	Invalid cartridge code.	Ensure 7-digit cartridge code is correct.
33	Unknown Test Type	Cartridge code invalid or analyzer software not compatible with test type.	Ensure 7-digit cartridge code is correct and analyzer software is up-to-date.
34	Code Format Error	Invalid cartridge code.	Ensure 7-digit cartridge code is correct.
35	Cartridge Expired	Cartridge has expired.	Use current, unexpired cartridge with correct 7-digit cartridge code.
36	Internal Instrument Error	Internal communication error.	Turn off and restart analyzer. If problem persists, contact Abaxis Technical Support.

### 6.3 Problems That Give No Advisory Message

**Problem:** Nothing happens when the analyzer is turned on.

**Action:** Ensure that the analyzer is connected to the power supply and that the power supply is connected to a power outlet. Check that the LED on the power supply is green. If the power supply LED is not lit, contact Abaxis Technical Support.

**Problem:** Test cartridge cannot be inserted in the VetScan VS*pro*.

**Action:** Ensure that there are no foreign objects in the cartridge slot.

**Problem:** The message **Please insert new cartridge** is still shown on the screen after the test cartridge has been inserted.

**Action:** Ensure that the cartridge is fully inserted in the cartridge slot.



# Collecting Blood Samples

## 7.1 Precautions Before Blood Sample Collection

- The precision and accuracy of VetScan VS*pro* tests is highly dependent on the quality of the blood sample.
- Test results can be significantly affected by how the blood sample is collected and handled.
- Contamination from anticoagulants other than sodium citrate, thromboplastin, alcohol, and intravenous solutions will interfere with the coagulation assay.
- Hemolysis and foaming of the blood sample are potential sources of erroneous test results.
- When collecting the blood sample, it is important to minimize the excitement of the patient. Excitement can cause splenic contraction, resulting in an increased cell count, and has been shown to increase platelet count and/or aggregation, levels of Von Willebrand factors, fibrinogen, and factors V and VIII, which have significant influence on the coagulation cascade.
- Sedatives, analgesics, and other medications can also affect blood coagulation.

## 7.2 Collecting Blood Samples

**Note:** For the order in which to fill sample collection tubes, see “Sample Tube Fill Order” on page 7-2.

1. Use a syringe that has an appropriate gauge needle to avoid mechanical hemolysis while obtaining the sample.
2. Clean the venipuncture site with alcohol and allow to air dry completely.
3. Collect blood directly into an evacuated tube containing sodium citrate (3.2%–3.8% concentration, blue top).

4. Allow the blood to be drawn into the blue top citrate tube until the flow stops.
5. Alternatively, the blood can be collected by filling the citrate tube by the natural blood flow.
6. It is very important to collect the appropriate amount of blood for the size of the citrate tube being used. Tubes must be filled to the manufacturer's recommended level to ensure accurate test results.
7. The appropriate amount of blood is usually indicated on the tube label. If there is no indication, fill the citrate tube to the top of the label.
8. Gently invert the blood-filled citrate tube 8–10 times to enhance the mixing of the blood sample and the citrate in the tube.

### 7.3 Sample Tube Fill Order

To prevent contamination, always fill sample collection tubes in this order:

1. **Red top:** No anticoagulant.

*Note: Use the red top tube only if necessary. If the red top tube is not needed, fill the green top tube first. But when needed, the red top tube must be filled before any other.*

2. **Green top:** Lithium heparin. Anticoagulant for chemistry only.
3. **Blue top:** Sodium citrate. Anticoagulant for coagulation only.
4. **Purple top:** EDTA. Anticoagulant for hematology only.

*Note: Do not use sodium citrate (blue-top tube) for any samples to be run on a chemistry or hematology analyzer.*

### 7.4 Handling Blood Samples

- Blood samples should be collected about 5 minutes before testing to stabilize the mixture of blood and the citrate.
- If testing is delayed, refer to the Test Specification section of the appropriate test for sample handling options.

### 7.5 General Requirements

- Do not use blood samples with visible clotting or debris accumulation.
- Do not use blood if the red blood cells settle unusually fast.
- Do not use blood that has been cooled or frozen.
- Do not use blood from a citrate tube that is over-filled or under-filled.
- Do not use blood stabilized with lithium heparin or EDTA.
- Do not use blood stabilized with sodium citrate for chemistry or hematology.

## 8.1 Introduction to PT/aPTT Testing

### Blood Coagulation

- Coagulation is the process in which blood forms clots through the formation of fibrin from fibrinogen.
- Coagulation theory simplifies blood clot formation into three interrelated pathways: the **intrinsic pathway** and the **extrinsic pathway**, both leading to the **common pathway** and the formation of a stable fibrin clot. See the figure on the following page.

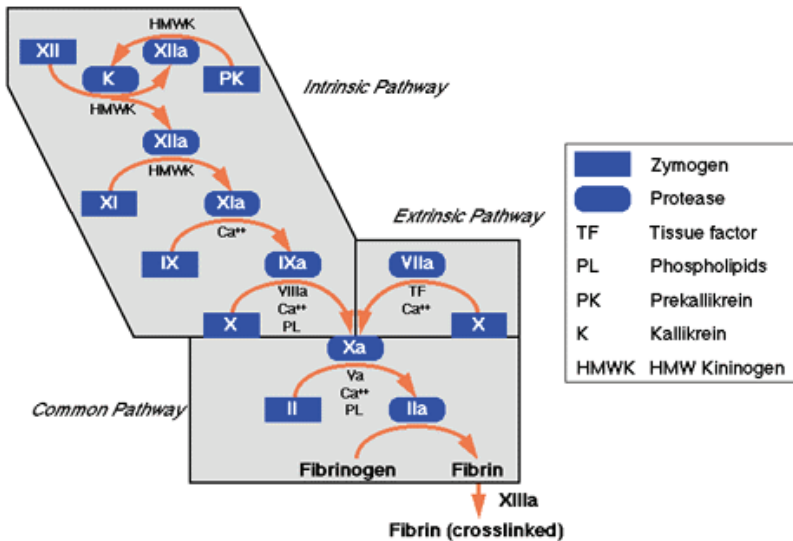

- The extrinsic pathway is initiated through the interaction of tissue factor with factor VII. Tissue factor is released from or exposed on the damaged tissue, disrupted cells, or cells such as macrophages, monocytes, or activated endothelial cells. In-vivo platelets, the essential cofactors in this reaction, provide the platelet phospholipid surface on which the coagulation occurs. Because the test reagents include phospholipid, thrombocytopenia does not affect this test.
- The intrinsic pathway is started through contact activation of factor XII. The pathway goes through several reactions that result in the formation of activated factor X.
- The common pathway uses factor X, factor V, and free calcium to create enzymatic conversion of prothrombin to thrombin, which is then used in creating fibrin from fibrinogen.
- Activated Partial Thromboplastin Time (aPTT) and Prothrombin Time (PT) tests are general coagulation tests used for screening and measuring the functionality of the blood coagulation cascade. PT is used to assess the extrinsic and common pathway and aPTT to assess the intrinsic and common pathway.

## PT/aPTT Combination Test Cartridge

The VetScan VS*pro* Specialty Analyzer and the PT/aPTT Combination Test cartridge are designed to detect and diagnose abnormalities in Prothrombin Time (PT) and Activated Partial Thromboplastin Time (aPTT).

Each VetScan VS*pro* PT/aPTT Combination Test cartridge contains two optical detection windows filled with micro-channels: one for detecting PT clotting time, the other for aPTT clot detection.

Each combination test cartridge can simultaneously measure PT and aPTT from a single drop of citrated whole blood. The nominal time for a PT/aPTT test takes about 10 minutes (including the warm-up times).

The PT/aPTT Combination Test requires the following:

### 1. Equipment:

- VetScan VS*pro* Specialty Analyzer
- VetScan VS*pro* PT/aPTT Combination Test cartridge
- Pipette (supplied with cartridge)

### 2. Blood sample:

- Whole blood collected in a blue-top tube containing sodium citrate (3.2%–3.8% concentration) per sample collection instructions.
- The blue-top tube must NOT be over- or under-filled.
- If possible, place the blood sample on a sample rocker. You can also invert the tube slowly 10 times every 10 minutes.
- Blood may be tested within two hours of collecting without affecting the results.

### 3. Optional: Printer and accessories for result printing

- Compatible USB-interface printer
- Printer paper
- USB cable

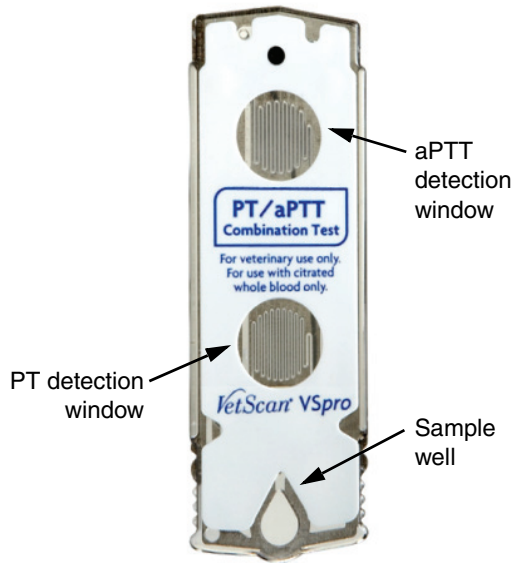

## PT/aPTT Combination Test Cartridge Storage and Precautions

- Each VetScan VS<sup>pro</sup> PTT/aPTT Test cartridge is individually packaged in a sealed pouch with a desiccant bag and a one-time-use disposable pipette.
- Store all cartridges at 2–8 °C (39–46 °F).
- Do not expose cartridges to direct sunlight or temperatures higher than 30 °C (86 °F).
- The cartridge is stable until the expiration date printed on its pouch label.
- Once a pouch is opened, the cartridge must be used within 10 minutes.
- Each cartridge can only be used once. *Do not reuse cartridges.*
- VetScan VS<sup>pro</sup> PTT/aPTT Combination Test cartridges can be used only with the VetScan VS<sup>pro</sup> Specialty Analyzer.
- Used test cartridges, pipette tips, and collection tubes are considered potentially infectious. Dispose of them properly in accordance with the policies and regulations of the place of operation.
- When collecting and handling blood samples or operating the VetScan VS<sup>pro</sup>, always strictly follow all biohazard safety guidelines pertaining to handling and disposing of animal blood samples.

## 8.2 PT/aPTT Combination Test Specifications

<b>Measurement technology</b>	Clot time, light absorbance		
<b>Result units</b>	Seconds		
<b>Reference ranges</b>	Species	PT (seconds)	aPTT (seconds)
	Dog	14–19	75–105
	Cat	15–21	94–125
<b>Dynamic range</b>	PT (seconds)	aPTT (seconds)	
	11–35	30–200	
<b>Sample type</b>	Whole blood		
<b>Sample volume</b>	100 µl of whole blood		
<b>Sample collection</b>	3.2%–3.8% concentration sodium citrate tube (blue top)		
<b>Sample stability</b>	2 hours at room temperature (15–30 °C, 59–86 °F). Invert the tube 10 times every 10 minutes.		
<b>Cartridge stability</b>	Do not expose cartridges in the foil pouch to direct sunlight, and do not leave at room temperature (15–30 °C, 59–86 °F) for more than 3 hours. Use cartridges taken from the foil pouch within 10 minutes.		
<b>Storage</b>	Refrigerate at 2–8°C (36–46°F)		
<b>Time to results</b>	Approximately 10 minutes		

### 8.3 PT/aPTT Combination Test Sample Preparation

1. Fill the sodium citrate (blue top) tube to the fill line with whole blood.

**Note:** *Over- or under-filled sample tubes may alter results due to an improper anticoagulant-to-sample ratio.*

2. After collection and before analysis, invert the blue-top tube 10 times to ensure proper mixture.

### 8.4 PT/aPTT Combination Test Procedure

**IMPORTANT:** *Before performing any tests, make sure the analyzer has been installed properly in accordance with the instructions in this manual.*

*Do not use excessive force or sharp objects on the analyzer's sensitive LCD touchscreen.*

1. Touch the **Analyze** button in the **Home** screen to start a test.

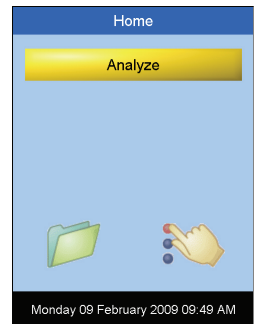

2. Make sure the analyzer's test cartridge slot is clear.
3. Open a VetScan VSpro PT/aPTT Combination Test cartridge pouch and remove the cartridge.
4. When the message **Please insert new cartridge** flashes on the screen, insert the new PT/aPTT Combination Test cartridge completely into the cartridge slot, with the label facing upward.

**Note:** *Never force a test cartridge into the cartridge slot. The cartridge should slide in easily.*

5. Find the cartridge code on the cartridge pouch label, and enter the cartridge code using the on-screen keyboard. Touch **Done**.

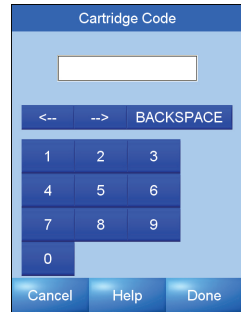

The screenshot shows a screen titled "Cartridge Code". At the top, there is a text input field. Below it is a navigation bar with left and right arrow icons and the text "BACKSPACE". Underneath is a numeric keypad with buttons for digits 1-9 and 0. At the bottom of the screen are three buttons: "Cancel", "Help", and "Done".

6. Select the species type: canine or feline. Touch **Done**.

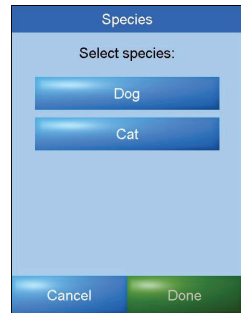

The screenshot shows a screen titled "Species". Below the title is the text "Select species:". There are two large blue buttons: "Dog" and "Cat". At the bottom of the screen are two buttons: "Cancel" and "Done".

7. Touch **Confirm** to acknowledge that the sample has been obtained in a citrate tube (blue top).

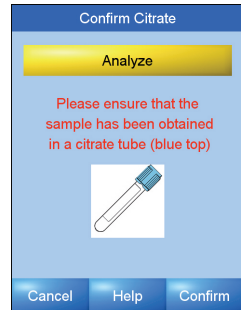

The screenshot shows a screen titled "Confirm Citrate". At the top is a yellow button labeled "Analyze". Below it is a red text message: "Please ensure that the sample has been obtained in a citrate tube (blue top)". Underneath the text is an image of a blue-top citrate tube. At the bottom of the screen are three buttons: "Cancel", "Help", and "Confirm".

8. Touch **Patient ID** to input the Patient ID information.

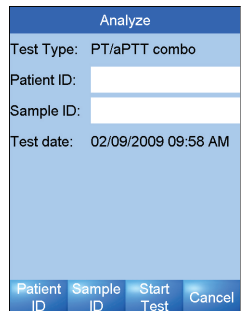

The screenshot shows a screen titled "Analyze". It contains the following text and input fields: "Test Type: PT/aPTT combo", "Patient ID:" followed by a text input field, "Sample ID:" followed by a text input field, and "Test date: 02/09/2009 09:58 AM". At the bottom of the screen are four buttons: "Patient ID", "Sample ID", "Start Test", and "Cancel".



9. An on-screen alphabetic or numeric keyboard opens. Touch **ABC** or **123** to switch between the keyboards.

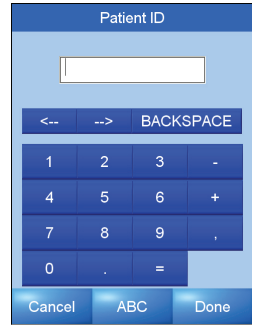

10. Use the on-screen keyboard to enter the Patient ID information.

11. Touch **Done**.

12. Touch **Sample ID** and use the on-screen keyboard to input the Sample ID information.

13. Touch **Done**.

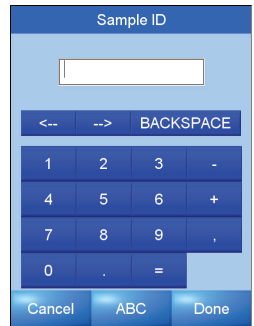

14. Touch **Start Test**. The **Cartridge Warming Up** screen opens.

**Note:** *It takes approximately 90 seconds for the analyzer to warm up the test cartridge.*

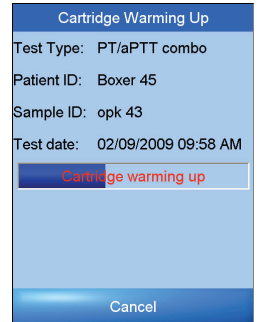

15. Gently invert the sample tube 10 times to obtain a uniform mixture of blood cells and plasma.

**IMPORTANT:** *Do not add blood to the sample well until instructed to do so on the screen. Do not add sample while the cartridge is warming up.*

16. When the analyzer beeps and flashes the message **Add blood and wait**, use the disposable pipette supplied with the cartridge to add one drop of blood sample to the sample well on the cartridge.

**Note:** *Be sure to fill the whole sample well with blood (at least 60  $\mu$ l).*

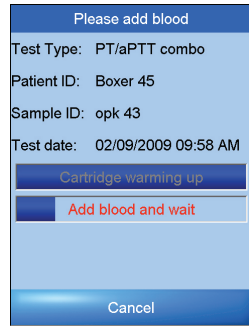

17. The measurement starts automatically when the analyzer detects the sample. Test progress flashes on the screen. The measurement usually takes about 5 minutes.

**Note:** *To cancel the measurement, touch the **Cancel** button.*

**Note:** *If the analyzer alerts you that an insufficient sample was placed into the sample well, repeat the measurement with a new test cartridge.*

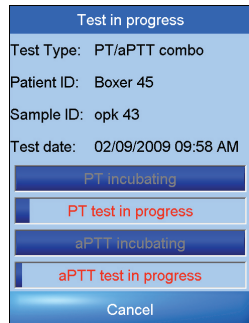

18. The test results are then displayed on the screen. If a printer is connected, touch **Print** on-screen to print the test results.

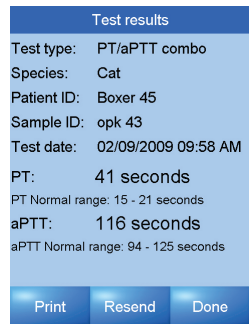

19. Touch **Done**. When the message **Please remove cartridge** appears, remove the used test cartridge and dispose of it properly.

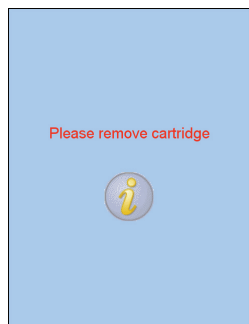

## 8.5 Test Performance

The time it takes to perform a measurement depends on factors such as the type of test and the test environment. At room temperature, it takes about 90 seconds for the analyzer to warm up the test cartridge to 37 °C (98.6 °F). Lower and higher ambient temperatures may impact the warm up time. Test results obtained under normal operating conditions have a CV (Coefficient of Variation) of 7% or less.

## 8.6 Limitations

The accuracy of tests run by the VetScan *VSpro* Specialty Analyzer depend on the quality of the blood sample, which in turn depends on how the sample is collected, the proper blood-to-citrate ratio, the proper mixing of the citrated blood, and the proper introduction of the sample into the cartridge sample well. **Always follow all directions and precautions in this manual, as well as good blood sampling techniques.**

As with any laboratory test result, consider signs, symptoms, and any other procedures before making a final diagnosis. Any test result that is inconsistent with a patient's status should be repeated and/or supplemented with additional testing.

Blood samples having a hematocrit less than 15% or greater than 65% are not recommended for use with the VetScan *VSpro*, and can cause errors.



# VSpro Fibrinogen Test

## 9.1 Introduction to Fibrinogen Testing

Fibrinogen is an acute phase protein (APP), used clinically as an indicator of acute or chronic systemic inflammation in horses. Acute phase proteins are quickly released into the bloodstream in response to infection or injury. Their blood levels are directly related to the severity of the underlying condition. By definition, APPs are those proteins in which plasma concentrations increase or decrease by at least 25% after an inflammatory stimulus.

Early recognition of systemic inflammation is essential for formulating and initiating an effective treatment plan. Inflammation that goes unrecognized or is sub-clinical can impair growth and performance.

### Fibrinogen Test Cartridge

The VetScan VSpro Specialty Analyzer together with the Fibrinogen Test cartridge is designed to evaluate the fibrinogen level in horses, a sensitive and specific marker of inflammation.

Each VetScan VSpro Fibrinogen Test cartridge contains optical detection windows that enable the absorbance of light to be measured through the sample mixture reacting with the active ingredient, thrombin.

Each test cartridge measures a single sample for a fibrinogen level from a single drop of platelet-poor plasma. The nominal time for a fibrinogen test is about 15 minutes (including warm-up).

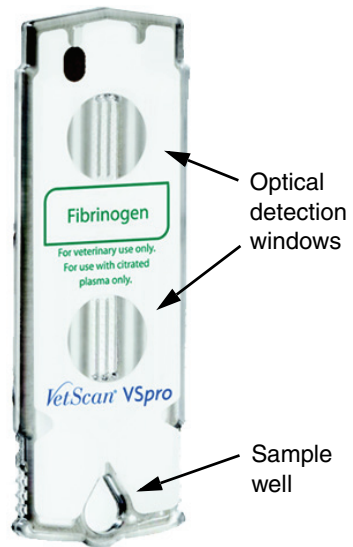

The Fibrinogen Test requires the following:

**1. Equipment:**

- VetScan VS*pro* Specialty Analyzer
- VetScan VS*pro* Fibrinogen Test cartridge
- The VS*pro* Specialty Analyzer must be calibrated to run the Fibrinogen Test cartridge. For calibration instructions, see page 9-17. (Calibration is *not* required to run a VetScan PT/aPTT Combination Test cartridge.)
- Pipette tip (included with the cartridge)
- Pipette
- Pre-filled diluent tube (included with the cartridge)
- Sodium citrate tube (3.2%–3.8% concentration, blue top)
- Centrifuge (min. 20,000g x minutes)

2. **Centrifuge:** The table below lists the required centrifugation time to obtain platelet-poor plasma as needed by the VetScan VS*pro* Fibrinogen Test.

Some centrifuges do not display the g loading of the sample, but instead show the revolutions per minute (RPM) of the centrifuge. In that case, use the table to find the required centrifugation time for a given RPM and centrifuge radius. (The centrifuge radius is the distance between the axis of rotation and the center of the test tube when placed in the centrifuge.)

Centrifuge radius (cm)	RPM	g	Req'd spin time (mins)
2.5	2000	112	179
2.5	3000	251	80
2.5	4000	447	45
2.5	5000	698	29
2.5	6000	1005	20
2.5	7000	1368	15
2.5	8000	1787	11
2.5	9000	2261	9
2.5	10,000	2792	7
5	2000	223	90
5	3000	502	40
5	4000	893	22
5	5000	1396	14
5	6000	2010	10

Centrifuge radius (cm)	RPM	g	Req'd spin time (mins)
5	7000	2736	7
5	8000	3573	6
5	9000	4522	4
5	10,000	5583	4
7.5	2000	335	60
7.5	3000	754	27
7.5	4000	1340	15
7.5	5000	2094	10
7.5	6000	3015	7
7.5	7000	4104	5
7.5	8000	5360	4
7.5	9000	6784	3
7.5	10,000	8375	2
10	2000	447	45
10	3000	1005	20
10	4000	1787	11
10	5000	2792	7
10	6000	4020	5
10	7000	5472	4
10	8000	7147	3
10	9000	9045	2

### 3. Blood sample:

- Whole blood collected in a blue-top tube containing sodium citrate (3.2%–3.8% concentration) per sample collection instructions.
- The blue-top tube must **not** be over- or under-filled.
- Do not place the sample on a rocker.
- At room temperature, whole blood samples placed in a sodium citrate (blue top) tube can be tested up to 24 hours after collection without affecting test results.
- Use a centrifuge (min. 20,000g x minutes) to spin the whole blood to platelet-poor plasma.
- At room temperature, plasma samples can be tested up to two hours after centrifuging without affecting test results.

#### 4. **Optional:** Printer and accessories for printing results

- Compatible USB interface printer
- Printer paper
- USB cable

#### **Fibrinogen Test Cartridge Storage and Precautions**

- Each VetScan VS*pro* Fibrinogen Test cartridge is individually packaged in a sealed pouch with a desiccant bag and a one-time-use disposable pipette tip.
- Store all cartridges at 2–8 °C (39–46 °F).
- Do not expose cartridges to direct sunlight or temperatures higher than 30 °C (86 °F).
- The cartridge is stable until the expiration date printed on its pouch label.
- Once a cartridge pouch is opened, the cartridge must be used within 10 minutes.
- Each cartridge can only be used once. *Do not reuse cartridges.*
- VetScan VS*pro* Fibrinogen Test cartridges can be used only with the VetScan VS*pro* Specialty Analyzer.
- Used test cartridges, pipette tips, and collection tubes are considered potentially infectious. Dispose of them properly in accordance with the policies and regulations of the place of operation.
- When collecting and handling blood samples or operating the VetScan VS*pro*, always strictly follow all biohazard safety guidelines pertaining to handling and disposing of animal blood samples.



## 9.2 Fibrinogen Test Specifications

<b>Measurement technology</b>	Light absorbance, turbidity-based plasma assay		
<b>Result units</b>	mg/dL, g/L, g/dL		
<b>Equine reference ranges</b>	<b>mg/dL</b>	<b>g/L</b>	<b>g/dL</b>
	150–400	1.5–4.0	0.15–0.40
<b>Dynamic range</b>	<b>mg/dL</b>	<b>g/L</b>	<b>g/dL</b>
	0.0–2000	0.0–20.0	0.0–2.0
<b>Sample type</b>	Platelet-poor plasma		
<b>Sample volume</b>	100 µL of platelet-poor plasma		
<b>Sample collection</b>	3.2%–3.8% concentration sodium citrate (blue top) tube		
<b>Sample stability</b>	<ul style="list-style-type: none"> <li>• 24 hours at room temperature (15–30 °C, 59–86 °F) for whole blood sodium citrate samples.</li> <li>• 2 hours at room temperature (15–30 °C, 59–86 °F) for plasma in a sodium citrate tube (blue top).</li> <li>• 30 days at freezing temperature (-10 °C, 14 °F) for plasma samples extracted from a sodium citrate (blue top) tube and placed in a red-top tube.</li> </ul>		
<b>Cartridge stability</b>	<ul style="list-style-type: none"> <li>• Do not expose cartridges in the foil pouch to direct sunlight, and do not leave them at room temperature (15–30 °C, 59–86 °F) for more than 3 hours.</li> <li>• Use cartridges taken from the foil pouch within 10 minutes.</li> </ul>		
<b>Storage</b>	Refrigerate at 2–8 °C (36–46 °F)		
<b>Time to results</b>	Approximately 15 minutes		

## Performance

### Precision

	Mean		SD	%CV	N
	g/L	mg/dL			
<b>Control 1</b>	3.73	373	0.16	4	20
<b>Control 2</b>	1.65	165	0.14	8	20

### Correlation

	Correlation Coefficient	Slope	Intercept	N
<b>Equine</b>	0.96	0.94	0.22	173

Plasma samples were analyzed using the VetScan VS*pro* Specialty Analyzer and the Beckman Coulter ACL Top Analyzer.

## 9.3 Customizing Fibrinogen Test Settings

Follow these instructions to change the units used for fibrinogen results, and to set annual calibration reminders.

1. Touch **Settings** in the **Home** screen. The **Settings** screen opens.
2. Touch **Customize**. The **Customize** screen opens.

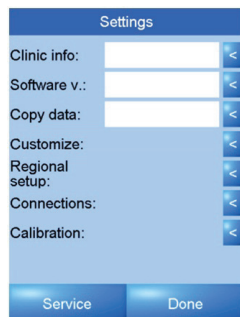
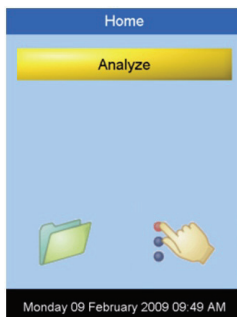

3. Touch the arrow  to the right of **Calibration reminder** as needed to select **Yes**.

**Note:** *Abaxis recommends displaying this reminder for the annual calibration needed to produce accurate fibrinogen test results. The reminder appears 12 months after the last calibration.*

4. Touch the arrow  to the right of **Fibrinogen unit** as needed to select the preferred units for fibrinogen results: **mg/dL**, **g/L**, or **g/dL**.
5. Touch **Done** to return to the **Settings** screen.

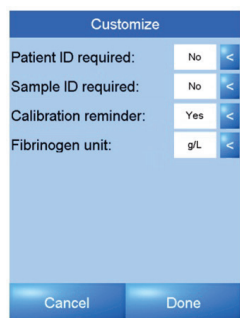

## 9.4 Calibrating the VSpro Analyzer for Fibrinogen Testing

The VetScan VSpro Analyzer must be calibrated annually to run the VetScan Fibrinogen Test cartridge.

### Equipment

- VetScan VSpro Specialty Analyzer
- VetScan VSpro Fibrinogen Calibration Kit
- Freeze-dried VetScan VSpro Fibrinogen Calibrator
- VetScan VSpro Fibrinogen Calibration Buffer
- Three VetScan VSpro Fibrinogen Calibration cartridges
- Pipette and three pipette tips

## Fibrinogen Calibration Preparation

**IMPORTANT:** *Store the calibration kit at 2–8 °C (36–46 °F), and allow it to reach room temperature before use.*

*Do not expose the calibration test kit to direct sunlight or temperatures higher than 30 °C (86 °F).*

*Once the VetScan VSpro Fibrinogen Calibration cartridge pouch is opened, it must be used within 30 minutes.*

*The calibration kit is functional until the expiration date printed on the cartridge pouch and box label.*

*Each VetScan VSpro Fibrinogen Calibration cartridge can only be used once.*

*The VetScan VSpro Fibrinogen Calibration cartridge can be used only with the VetScan VSpro Analyzer.*

*The VetScan VSpro Fibrinogen Calibration cartridge can only be used to calibrate the VetScan VSpro Analyzer for the Fibrinogen Test cartridge.*

**CAUTION:** *Do not use VetScan VSpro Fibrinogen Calibration cartridges that are damaged, past their expiration date, or have been improperly stored.*

**WARNING:** *The calibrator is based on human fibrinogen. Abaxis recommends wearing appropriate gloves when working with the calibrator fluid.*

*When working with the calibrator fluid, always strictly adhere to all biohazard safety guidelines pertaining to handling and disposing of samples containing human blood fraction products.*

### Prepare the Calibrator Fluid

1. Without opening the VetScan VSpro Fibrinogen Calibration Buffer, tap the cap of the bottle to release any liquid caught in the bottle cap.
2. Remove the cap from the bottle of VetScan VSpro Fibrinogen Calibration Buffer.
3. Remove the cap from the bottle of freeze-dried VetScan VSpro Fibrinogen Calibrator.

4. Pour the VetScan VSpro Fibrinogen Calibration Buffer into the bottle of freeze-dried VetScan VSpro Fibrinogen Calibrator. *Make sure no buffer remains in the tube.*

**CAUTION:** *All liquid from the VetScan VSpro Fibrinogen Calibration Buffer bottle must be transferred to the bottle of freeze-dried VetScan VSpro Fibrinogen Calibrator. If any liquid remains in the bottle or is spilled, the calibration will not be correct.*

5. Replace the cap on the VSpro Fibrinogen Calibrator bottle. Make sure the cap is securely fastened.
6. Gently swirl the bottle for one minute until the freeze-dried calibrator is completely dissolved, so that the calibrator fluid is fully returned to liquid form (reconstituted).
7. Let the reconstituted VetScan VSpro Fibrinogen Calibrator sit for 15 minutes, and swirl once every 5 minutes.

## 9.5 Fibrinogen Calibration Procedure

**IMPORTANT:** *Before performing the calibration, make sure the VetScan VSpro Specialty Analyzer software has been updated according to the instructions in the VetScan VSpro Specialty Analyzer Operator's Manual, and that the calibrator fluid has been prepared as described on page 9-7.*

1. Remove the VetScan VSpro Fibrinogen Calibration cartridges from refrigeration, and allow them to warm to room temperature (15–30 °C, 59–86 °F).
2. Touch **Settings** in the **Home** screen. The **Settings** screen then opens.

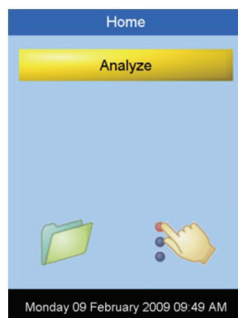

3. Touch the arrow  to the right of **Calibration**. The **Calibration** screen then opens.

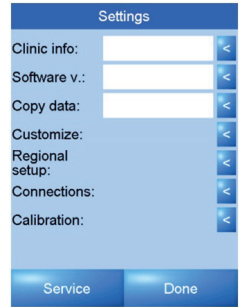

4. In the **Calibration** screen, touch **Calibrate**. The **Confirm** screen then opens.

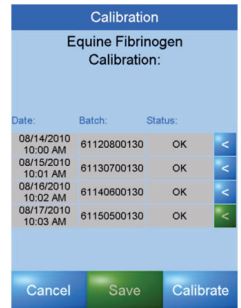

5. Touch **Confirm** if the fluid has been prepared according to the instructions on page 9-7. Otherwise, touch **Cancel**.

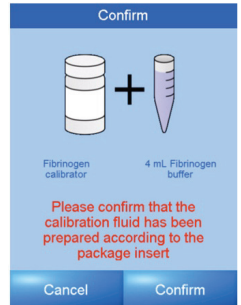

6. Use the on-screen keyboard to enter the 11-digit calibration code from the bottle of freeze-dried VetScan *VSp<sub>ro</sub>* Fibrinogen Calibrator.

7. Touch **Done**.



8. When the message **Please insert cartridge 1 of 3** appears, open the first pouch and insert the enclosed VSpro Fibrinogen Calibration cartridge in the cartridge slot. The instrument automatically starts the calibration by heating the cartridge.

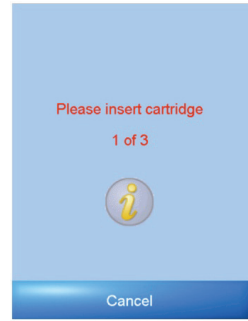

9. Gently swirl the bottle containing calibrator fluid to obtain a uniform mixture. When the message **Add 100 µL sample and wait** appears, use the supplied pipette and pipette tip to add 100 µl of calibrator fluid to the sample well.

*Note: Avoid introducing bubbles to the sample well.*

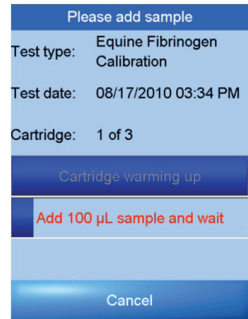

10. Discard the pipette tip.
11. After 12 minutes, part one of the calibration finishes, and the analyzer prompts you to remove the cartridge. Remove and discard the cartridge.

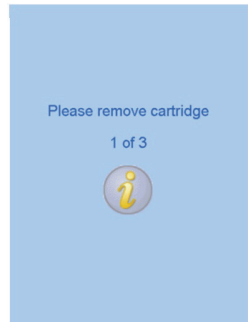

12. When the message **Please insert cartridge 2 of 3** appears, open the second pouch and insert a new VSpro Fibrinogen Calibration cartridge in the cartridge slot. The instrument automatically starts the calibration by heating the cartridge.

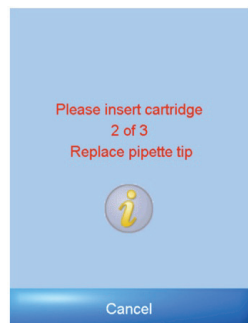

13. Attach the new pipette tip from the cartridge pouch to the pipette. When the message **Add sample and wait** appears, use the pipette to add 100 µl of calibrator fluid to the sample well.

*Note:* Avoid introducing bubbles to the sample well.

14. Discard the pipette tip.

15. After 12 minutes, part two of the calibration finishes, and the analyzer prompts you to remove the cartridge. Remove and discard the cartridge.

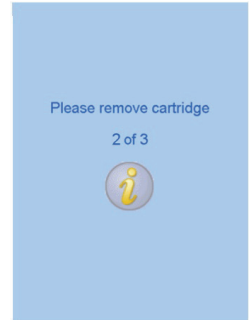

16. When the message **Please insert cartridge 3 of 3** appears, open the third pouch and insert a new VS<sub>pro</sub> Fibrinogen Calibration cartridge in the cartridge slot. The instrument automatically starts the calibration by heating the cartridge.

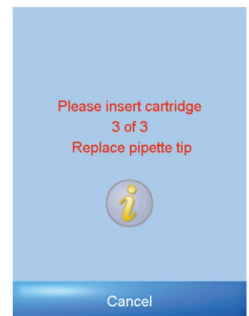

17. Attach the new pipette tip from the cartridge pouch to the pipette. When the analyzer displays **Add sample and wait**, use the pipette to add 100 µl of calibrator fluid to the sample well.

*Note:* Avoid introducing bubbles to the sample well.

18. Discard the pipette tip.

19. After 12 minutes, part three of the calibration finishes, and the analyzer prompts you to remove the cartridge. Remove and discard the cartridge.

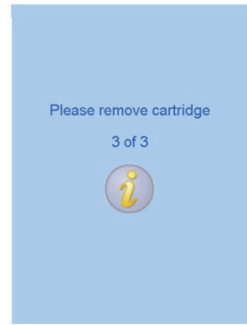

20. Touch **Done**. The **Calibration results** screen then opens and displays **Analyzer calibrated successfully**.

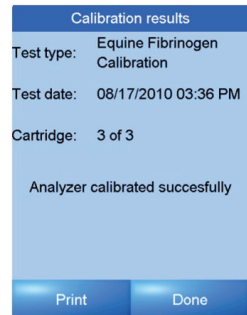

21. Touch **Done** to return to the **Home** screen.

22. To check the calibration history, touch the **Settings** button in the **Home** screen, then touch the arrow  to the right of **Calibration**.

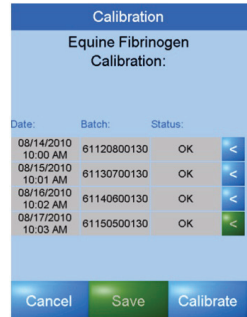

**Note:** *If you have any questions or concerns during calibration, contact Abaxis Technical Support at 800-822-2947, 24 hours a day, 7 days a week.*



## 9.6 Preparing Fibrinogen Test Samples

**IMPORTANT:** *Do not use blood that is over-filled or under-filled in the citrate tube.*

*Do not use blood samples with visible clotting or debris.*

*Do not use blood that was stabilized in any way other than in the prescribed sodium citrate tube.*

*Do not use plasma from samples that were centrifuged at less than 20,000g x minutes. See page 9-2.*

*Do not use plasma exhibiting signs of RBCs, hemolysis, lipemia, or other conditions that may affect turbidity.*

1. Fill the sodium citrate tube (blue top) to the fill line with whole blood.
2. Use a centrifuge to spin whole blood samples to platelet-poor plasma. See page 9-2 for centrifuge requirements and spin times.
3. Remove the lid from the supplied pre-filled diluent microtube. Make sure no diluent remains in the lid.

4. Use a pipette and the supplied pipette tip to transfer 100  $\mu$ L of platelet-poor plasma from the blue-top tube to the pre-filled diluent microtube.

5. Gently invert the microtube five times to uniformly mix the plasma and diluent. Do not place the microtube on a rocker.

6. Just before analysis, invert the microtube five more times to ensure a proper mixture.

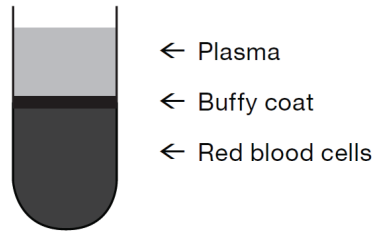

## 9.7 Fibrinogen Test Procedure

**IMPORTANT:** Before performing any tests, make sure the analyzer has been installed properly in accordance with the instructions in this manual.

*Do not use excessive force or sharp objects on the analyzer's sensitive LCD touchscreen.*

1. Remove the Fibrinogen Test cartridge from refrigeration, and allow it to warm to room temperature (15–30 °C, 59–86 °F) for approximately 15 minutes.

**Note:** Only open the test cartridge pouch immediately before use.

2. Make sure the analyzer's test cartridge slot is clear.
3. Touch the **Analyze** button in the **Home** screen to start a test.

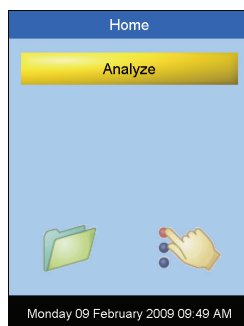

4. When the message **Please insert new cartridge** flashes on the screen, insert a new VetScan VSpro Fibrinogen Test cartridge all the way into the cartridge slot, with the label facing upward and the sample well facing outward.

**Note:** Never force a test cartridge into the cartridge slot. The cartridge should slide in easily.

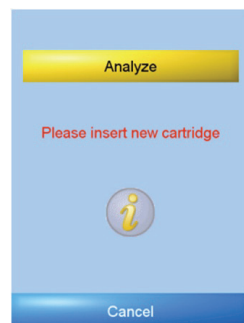

5. Use the on-screen keyboard to enter the 7-digit cartridge code from the cartridge pouch label. Touch **Done**.

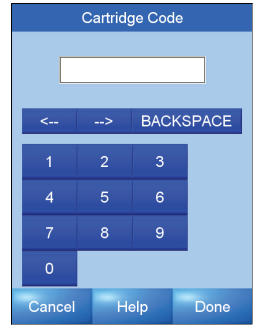

6. Touch **Confirm** to acknowledge that the sample has been obtained in a sodium citrate tube (blue top), spun to platelet-poor plasma, and diluted by adding 100 µL of plasma to the supplied pre-filled diluent microtube.

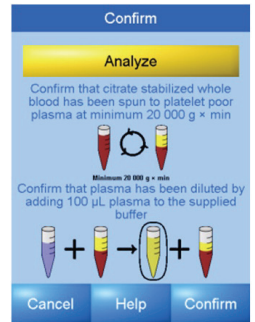

7. Touch **Patient ID** to input the Patient ID information.

*Note: Sample ID and Patient ID are optional. Information entered here appears in the Memory Database and in result printouts.*

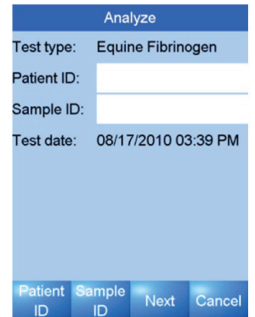

8. An on-screen alphabetic or numeric keyboard opens. Touch **ABC** or **123** to switch between the keyboards.
9. Use the on-screen keyboard to enter the Patient ID information.
10. Touch **Done**.

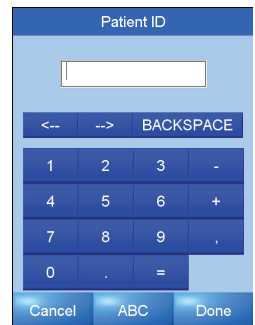
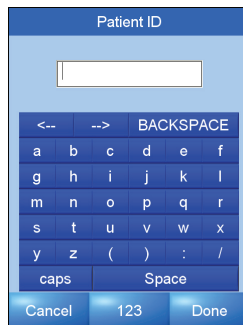

11. Touch **Sample ID**, then use the on-screen keyboard to input the Sample ID information.
12. Touch **Done**.

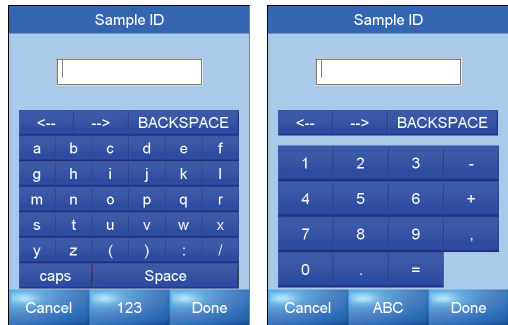

13. Touch **Next** on the **Analyze** screen. The **Cartridge warming up** screen opens.

**Note:** *It takes approximately 5 minutes for the analyzer to warm the test cartridge.*

14. Gently invert the microtube five times to obtain a uniform mixture of plasma and diluent.

**IMPORTANT:** *Do not add diluted plasma sample to the sample well until instructed to do so on the screen. Do not add sample while the cartridge is warming up.*

15. When the analyzer beeps and flashes the message **Add 100  $\mu$ L of sample and wait**, use the pipette and pipette tip to add 100  $\mu$ L of sample to the sample well on the cartridge.

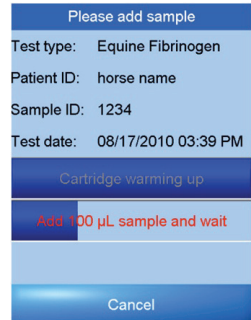

16. The measurement starts automatically when the analyzer detects the sample. Test progress flashes on the screen. The measurement usually takes about 10 minutes.

**Note:** To cancel the measurement, touch the **Cancel** button.

*Do not refill if an inadequate sample volume has been added to the sample well. Repeat the measurement with a new test cartridge.*

17. The test results are then displayed on the screen. If a printer is connected, touch **Print** to print the test results.

18. Touch **Done**. When the message **Please remove cartridge** appears, remove the used test cartridge and dispose of it properly.

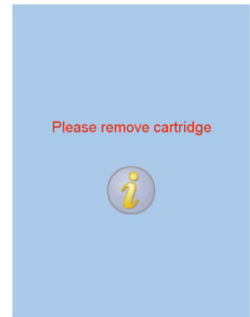
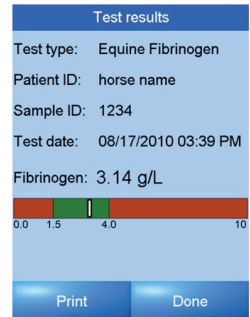
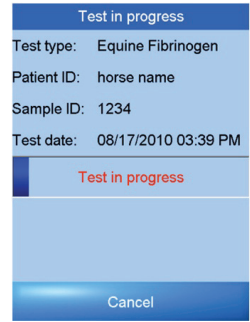

## 9.8 Test Performance

The time it takes to perform a measurement depends on factors such as the type of test and the test environment. At room temperature, it takes about 5 minutes for the analyzer to warm up the test cartridge to 37 °C (98.6 °F). Lower and higher ambient temperatures may impact the warm up time. Test results obtained under normal operating conditions have a CV (Coefficient of Variation) of 7% or less.

## 9.9 Limitations

The accuracy of tests run by the VetScan *VSpro* Specialty Analyzer depend on the quality of the blood sample, which in turn depends on how the sample is collected, the proper blood-to-citrate ratio, mixing of the citrated blood, centrifugation, dilution of plasma, and introduction of the sample into the cartridge sample well.

**Always follow all directions and precautions in this manual, as well as good blood sampling techniques.**

As with any laboratory test result, consider signs, symptoms, and any other procedures before making a final diagnosis. Any test result inconsistent with a patient's status should be repeated and/or supplemented with additional testing.

## A

---

Abaxis Customer Mailing List 2-1  
Abaxis Technical Support 1-2, 5-3, 6-1  
Activated Partial Thromboplastin Time (aPTT) 8-2  
Advisory Messages 6-2  
Analyze Menu 2-5

## B

---

Blood Coagulation 8-1, 8-2  
Blood Samples  
    Collecting 7-1  
    Collection Times 7-2  
    General Requirements 7-2  
    Handling 7-2  
    Precautions 7-1  
Blue Top Tube 7-2, 8-3

## C

---

Calibration (Fibrinogen Test) 9-6  
    Cartridge 9-6  
Cartridge (Calibration) 9-6  
Cartridge (Test)  
    Features 1-1  
    Fibrinogen 9-1  
    Fibrinogen, Storage and Precautions 9-4  
    PT/aPTT Combination 8-3, 8-6  
    Storage and Precautions 8-4  
Cartridge Code  
    Fibrinogen Test 9-15  
    PT/aPTT Test 8-6  
Centrifuge for Fibrinogen Testing 9-2  
Cleaning 5-1  
Coefficient of Variation (CV), Test 8-9, 9-17  
Confirm Screen (Fibrinogen Test) 9-15

## D

---

Data, Copying from Analyzer 3-4, 9-4  
Date  
    Changing 3-2, 9-2  
    Changing Format 3-3, 9-3

## E

---

EDTA 7-2  
Environmental Requirements 2-4

## F

---

Fibrinogen Test  
    Calibration Cartridge 9-6  
    Calibration For 9-6  
    Cartridge 9-1  
    Cartridge Code 9-15  
    Confirming Sample Properties 9-15  
    Customizing Settings 9-6  
    Limitations 9-18  
    Performance 9-17  
    Procedure 9-14  
    Required Equipment and Materials 9-1  
    Sample Preparation 9-13  
    Specifications 9-5

- H

---

- Help Screens 2-5
- Home Screen 2-5
- K

---

- Keyboard
  - External 3-4
  - On-Screen 8-7, 9-15
- L

---

- Language, Changing 3-4, 9-4
- Lithium Heparin 7-2
- M

---

- Maintenance 5-1
- Memory Menu 2-5
- O

---

- Operating Principles 1-2
- Operator's Manual 2-1
- P

---

- Performance
  - Fibrinogen Test 9-17
  - PT/aPTT Combination Test 8-9
- Power Adapter 2-1
- Power Supply 1-4
  - Precautions 2-4
  - Specifications 2-3
- Precautions 1-4
  - Blood Samples 7-1
  - Cleaning 5-1
  - Power Supply 2-4
- Printing Test Results
  - Fibrinogen 9-17
  - PT/aPTT Combination 8-8
  - Requirements 8-3, 9-4
- Prothrombin Time (PT) 8-2
- PT/aPTT Combination Test 8-1
  - Cartridge 8-3, 8-6
  - Cartridge Code 8-6
  - Limitations 8-9
  - Performance 8-9
  - Printing Results 8-8
  - Procedure 8-5
  - Required Equipment and Materials 8-1
  - Sample Preparation 8-5
  - Specifications 8-4
- PT/aPTT Combination Tests
  - Performance, PT/aPTT Combination 8-9
- Q

---

- Quick Reference Guide 2-1
- S

---

- Safety Information 1-4
- Sample Preparation
  - Fibrinogen Test 9-13
  - PT/aPTT Combination Test 8-5
- Sample Tubes 7-2
  - Blue Top 7-2, 8-3
  - Order of Use 7-2
- Self-Test 2-4
- Settings Menu 2-5, 3-1, 9-1
- Setup 2-1, 2-4
- Sodium Citrate 7-2
- Software
  - Update 3-3, 9-3
  - Version 3-3, 9-3
- Specifications
  - Analyzer 2-3
  - Environmental 2-3
  - Fibrinogen Test 9-5
  - PT/aPTT Combination Test 8-4
- Support, Obtaining 5-3
- Symbols 1-3
- T

---

- Tests
  - Fibrinogen Cartridge 9-1
  - Fibrinogen Specifications 9-5
  - Fibrinogen Test Cartridge Storage and Precautions 9-4
  - Limitations, Fibrinogen 9-18
  - Limitations, PT/aPTT Combination 8-9
  - Memory Database 4-1
  - Performance, Fibrinogen 9-17
  - Performance, PT/aPTT Combination 8-9
  - Printing Requirements 8-3, 9-4
  - Printing Results, Fibrinogen 9-17
  - Procedure, Fibrinogen 9-1
  - Procedure, PT/aPTT Combination 8-1
  - PT/aPTT Combination Test Cartridge Storage and Precautions 8-4
  - Searching Results 4-2
  - Viewing Results 4-1
- Time, Changing 3-2, 9-2
- Touchscreen 1-4, 3-1, 9-1
- Troubleshooting 6-1, 6-4
- U

---

- User Information 1-4
- V

---

- VetScan VS*pro* Specialty Analyzer 1-1, 1-2
  - Cleaning 5-1
  - Components 1-1, 2-2
  - Configuring 3-1, 9-1
  - Environmental Requirements 2-4
  - Maintenance 5-1
  - Obtaining Support 5-3
  - Operating Principles 1-2
  - Precautions and Warnings 1-4
  - Setting Up 2-4
  - Software 3-3, 9-3
  - Specifications 2-3
  - Troubleshooting 6-1, 6-4
  - User Information 1-4