



## T-BERD®/MTS-8000 Transport Module

SONET/SDH, PDH, Fibre Channel, OTN, Jitter,  
Wander, and Ethernet



As communication providers strive to improve their Metro network service turn-up processes, they must provide customers with expected service quality levels. Closely coupled to this goal is the ability to verify that the network is performing acceptably when customers complain that their applications are slow due to the network.

The Viavi Solutions T-BERD/MTS-8000 Transport Module answers the call by providing the most complete Metro test solution on the market, including advanced features for Layer 4 and above application-centric testing, IPTV testing, and Fibre Channel (FC) testing up to 10 Gb/s.

Application-centric testing goes beyond traditional Layer 2/Layer 3 (L2/L3) Ethernet- and Internet Protocol (IP)-based network-centric turn-up to ensure that customer applications perform satisfactorily. Customer applications (Layer 4 [L4] and above) can perform poorly even over carrier networks previously tested for proper L2/L3 performance, or acceptable throughput, packet loss, delay, and jitter. The Transport Module provides application-centric turn-up testing to qualify networks, helping eliminate improper carrier network configuration issues and helping carriers defend the performance of their network while providing solid customer recommendations for possible enterprise equipment issues.

The comprehensive IP television (IPTV) test capabilities of the Transport Module enable verification of video service deployment and quality of service (QoS) in transport networks.

### Key Features

- Supports 10 Mb/s to 10 Gb/s interface IPTV testing
- Provides Layer 4+ application-centric turn-up testing for TCP/UDP, FTP, and HTTP emulation
- Simultaneous and independent multi-port SONET, SDH, OTN, FC, and Ethernet test capable
- Supports optical GigE, 10 GigE LAN and WAN PHY testing at 850, 1310, and 1550 nm wavelengths
- 1/2/4/10G FC and FICON support for SANs with automated FC testing and buffer-to-buffer control verification
- Supports PDH and optical SONET/SDH testing for T1 and 10 Gb/s
- Supports OTN testing at 2.7, 10.7, 11.05, and 11.1 Gb/s bit rates with SONET/SDH and Ethernet client emulation
- Supports O172/O173-compliant jitter and wander testing for T1, E1, E3, DS3, E4, STM-1 (e/o) electrical rates as well as 155 M, 622 M and 2.5 G, 2.7 G optical interfaces
- Supports testing and troubleshooting up to 40 G SONET/SDH and 43 G OTN

With 4 and 10 G FC functionality, the Transport Module helps maximize storage area network (SAN) business potential. A breakthrough in economy and efficiency, the Transport Module leverages providers' existing investments in equipment and technician training. Using the T-BERD/MTS 8000, technicians can install and maintain SAN-related links and test to ensure that they meet service level agreements (SLAs).

The T-BERD/MTS-8000 Transport Module enables even relatively new technicians to perform a full suite of advanced tests. This reference guide provides an overview of the T-BERD/MTS-8000 Transport and Metro product line and its features that are trusted by customers worldwide.

## Overview

### One Integrated Solution

As new service offerings arise, Multiservice Provisioning Platforms (MSPPs) are combining data and transport technologies on the same line cards. These network elements (NEs) offer providers the flexibility to configure new services quickly to support customer demand. The Transport Module replicates this design by providing Ethernet, optical transport network (OTN), FC, jitter, wander, synchronous optical network/synchronous digital hierarchy (SONET/SDH), and plesiochronous digital hierarchy (PDH) test functionality in one module, enabling providers to deploy, commission, and maintain these new services quickly, efficiently, and conveniently. Users are no longer required to carry and maintain multiple modules or test sets in support of today's service offerings.

### Most Extensive Testing Capabilities

The Transport Module's simultaneous test capability allows users to test the bit error rate (BER) of three circuits in parallel, and perform dual direction, in line optical monitoring (seeing both East and West directions) for SONET/SDH rings, FC, and Gigabit Ethernet (GigE) services. The IP Video Test Suite provides verification of video service connectivity and Motion Pictures Expert Group 2 (MPEG-2) Transport Stream analysis. The Transport Module provides end-to-end L4 Transmission Control Protocol/User Datagram Protocol (TCP/UDP) Traffic Blasting that measures throughput, loss, and delay, as well as TCP state—full emulation is also provided with the ability to map throughput performance over various Window sizes. These higher-layer applications allow providers to verify L2 and L3 SLAs, as well as perform application-centric service installation.

### Support for Small Form-factor Pluggable Modules

Technicians can add testing capability with small form-factor pluggable modules (SFPs) to create a wide range of field-configurable optical electrical test combinations. Technicians can reconfigure the unit instantaneously with optics, and service providers can save money by providing technicians with only the optics they need. Viavi provides a wide range of SFP optics and the Transport Module can also use SFPs from third parties.



Port view of T-BERD/MTS-8000 Transport Module

## Very Easy to Use

The graphical user interface (GUI) of the Transport Module makes it easy for even relatively inexperienced technicians to perform a broad range of tests, as Figure 1 shows. The screen displays test results stacked in layers on top of each other, with each OK indicated in green and errors indicated in red. Tabular results are provided in the form of graphs for easier understanding, such as throughput, frame loss, delay, and jitter presented as functions of time. Wizard-driven scripts now automate formerly complicated testing procedures. For example, the Walk the Window script automates the process of determining the proper TCP Send Window size. Scripts are also provided to determine File Transfer Protocol (FTP) and Hypertext Transfer Protocol (HTTP) throughput.

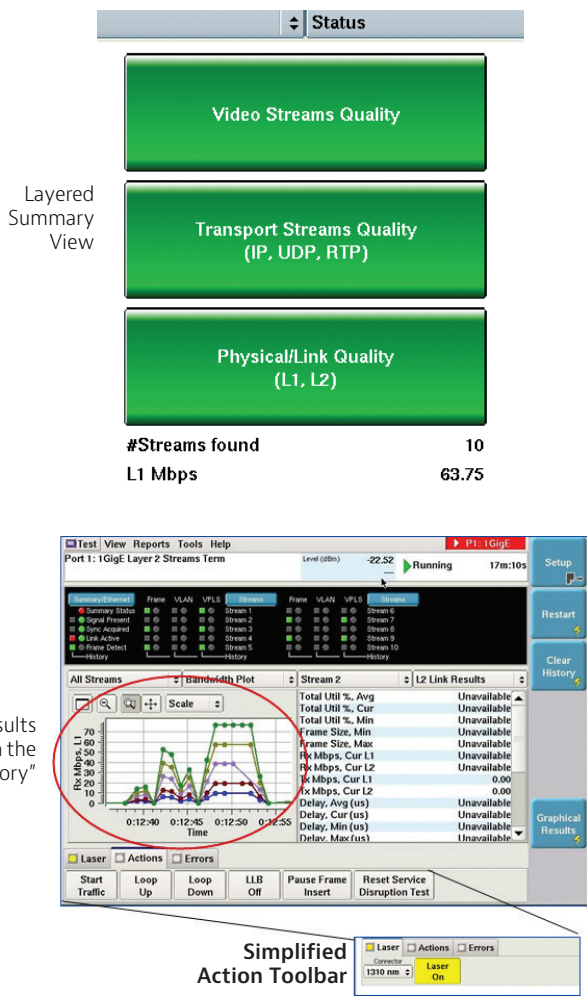

Figure 1. The Transport Module GUIs make it easy for even relatively inexperienced technicians to perform a broad range of tests

## Ethernet and IP

The Transport Module provides the industry's most powerful platform for the installation and maintenance of carrier-grade Ethernet and IP services and also enables transport technicians to quickly turn up and maintain Metro Core networks. It can verify end-to-end connectivity, measure BER, and determine whether throughput, utilization, frame loss, packet jitter, and round-trip delay (RTD) characteristics meet SLA agreements. It can perform Ethernet and SONET/SDH tests at line rates from 10 Mb/s to 10 Gb/s. The Transport Module can test a wide range of mechanism and tunneling technologies, including 10 GigE within 11.05 and 11.1 Gb/s OTN. It can also verify the full transparency of Layer 2 (L2) networks by generating and analyzing a large number of control plane frames, which users can customize.

## Powerful IPTV Test Abilities

The Transport Module provides comprehensive IPTV test capabilities. The Transport Module provides comprehensive IPTV test capabilities. Technicians can verify network provisioning by accessing video streams at various network points and analyzing receipt of the streams and their QoS at each point. This capability enables them to verify that the physical, transport, and video stream layers are free of errors and alarms. Technicians can also perform detailed troubleshooting by selecting streams to verify transport layer conditions, including packet loss, jitter, media delivery index (MDI), distance error, and period errors. Technicians can also verify video stream layer conditions, including program clock reference (PCR) jitter, sync loss errors, and continuity counter errors, such as video packet loss, transport error indicators, and packet identification (PID) errors. Figure 2 provides an example of the detail provided about IPTV transport stream quality.

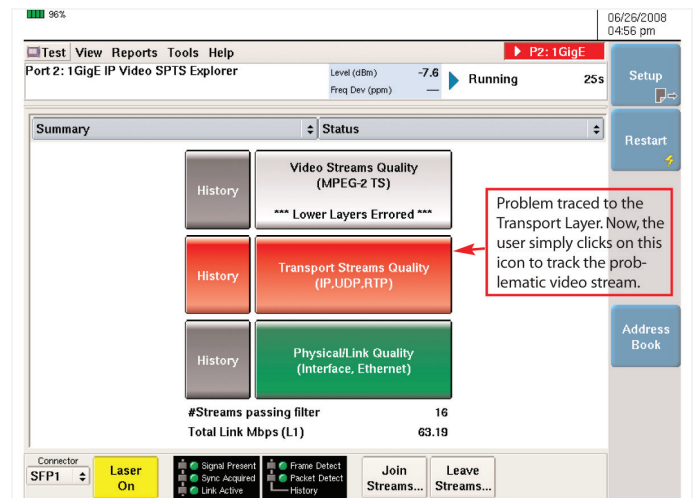

Figure 2. The T-BERD/MTS-8000 Video Discovery feature points to transport stream quality issues

### Quality of Service Measurements Testing with Multiple Streams

The Transport Module relies on multiple stream traffic generation, allowing users to emulate various types of traffic with the appropriate Class of Service (CoS) mappings and assess the impact of such traffic on the overall network design, as Figures 3 and 4 illustrate.

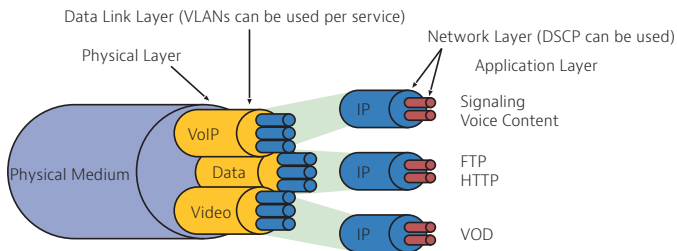

Figure 3. Multiple Data Streams

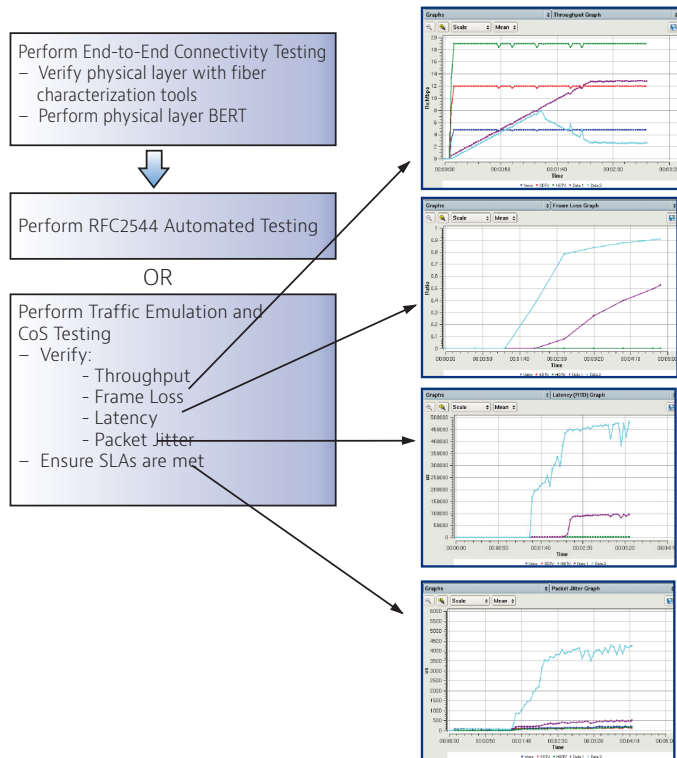

Figure 4. QoS testing

### PBB/PBT, VLAN, Q-in-Q, VPLS, and MPLS Tunneling Technologies

Various mechanism and tunneling technologies available today let providers effectively deliver carrier-grade Ethernet services across their networks, while maintaining a specified CoS. These technologies are grouped into categories:

- Native Ethernet protocol extensions (IEEE-based)—Virtual LAN (VLAN) tags (often referred to as 802.1q/p) and Q-in-Q (often referred to as VLAN stacking or 802.1ad) techniques
- Provider Backbone Bridged (PBB), and Provider Backbone Bridged Transport (PBT)
- Encapsulations by Multi-Protocol Label Switching (MPLS) networks, which also come in L2 (Virtual Private LAN Service, VPLS) and L3 versions

The Multi-Services Application Module enables the installation and maintenance of these technologies.

### Application-Centric Layer 4 and Higher Turn-up

The Transport Module offers L4 and higher Application-Centric Turn-up that enables technicians to go beyond the traditional Ethernet service turn-up process that verifies the ability of the network to meet SLAs for L2 (Ethernet) and L3 (IP) performance. Upon completion of the basic connectivity and throughput testing, the Transport Module Triple-Play Turn-up test application can be used to simplify the test and verification of a network's ability to carry Triple-Play Traffic. Users simply configure the desired number of representative standard definition (SDTV) and high definition (HDTV) television channels along with voice calls and data traffic, and the unit presents an easy-to-understand summary screen shown in Figure 5, including a network pipe diagram shown in Figure 6.

## Scripts Automate TCP Window Optimization, FTP and HTTP Throughput Testing

The Transport Module automates the process of setting the TCP Window, which is critical to an application's performance. The Walk the Window script tests performance over a range of window sizes and provides an easy-to-understand test report that clearly highlights the optimal Window size. The Transport Module also simplifies FTP and HTTP throughput testing with a wizard-like configuration interface. The FTP test results show FTP upload and download throughput for a wide range of file sizes. The HTTP throughput test is run with a live Web server and the test report highlights the Web page sizes versus throughput for each universal resource locator (URL).

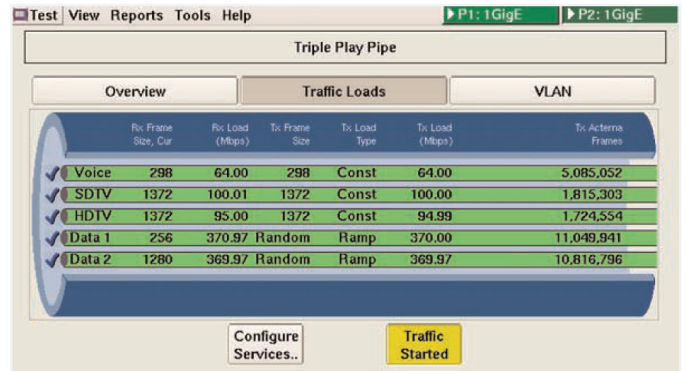

Figure 6. Triple-Play Summary Network Pipe Screen

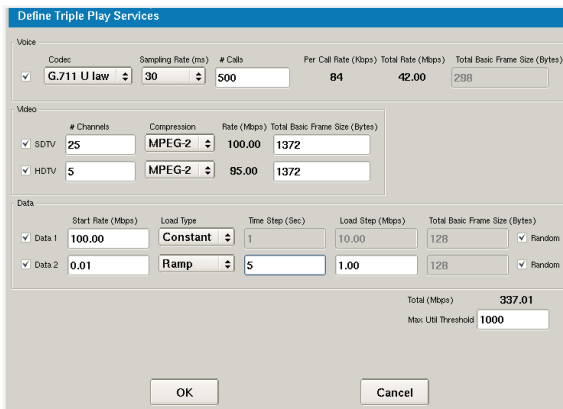

Figure 5. Configuring Triple-Play Profiles

# Storage Area Networking

## Fibre Channel/ FICON Overview

The Transport Module tests 1, 2, 4, and 10 Gb/s FC and fiber connection (FICON) services. Users can manipulate various fields of the FC frames to emulate end-customer traffic and perform BER measurements on L1 and L2 circuits. The Transport Module supports buffer crediting capability, which lets providers verify the effect of delay on the link throughput and test the ability of the link to obtain the optimum buffer credit values. The Transport Module also allows users to turn up SANs efficiently using the FC automated test script producing reliable throughput, packet loss, RTD, and burstability results with a consistent test methodology. Figure 7 displays an example of a testing in a SAN.

## 'RFC-Like' Fibre Channel Testing

- Adapts RFC2544 testing methodology to FC circuits
- Allows for automated test routines and results analysis
- Allows for the saving of specific test configurations and routines

The Transport Module provides an automated test routine and results analysis that can be configured to automatically verify the optimal buffer credit size to meet the desire SLAs of the link by:

1. Finding the optimal buffer size
2. Calculating the minimum buffer credit size for the specified throughput at each frame length (see Table 1)
3. Measuring the throughput at various buffer credit size (see Table 2)

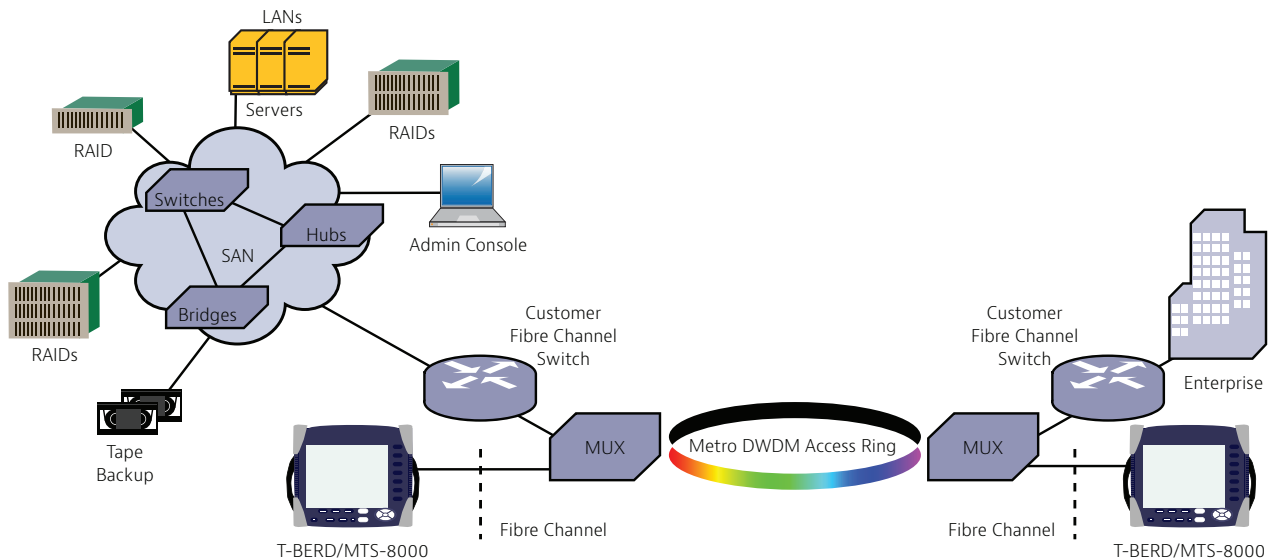

Figure 7. Storage area network

Table 1. Buffer credit test results

Frame Length (Bytes)	Cfg Rate (Mb/s)	Minimum Buffer Size (Credits)
76	1700.0	375
128	1700.0	278
256	1700.0	155
512	1700.0	83
1024	1700.0	43
1536	1700.0	30
2076	1700.0	22
2140	1700.0	22

Table 2. Throughput at incremental buffer credit size

Frame Length (Bytes)	Buffer Size (Credits)	Cfg Rate (Mb/s)	Measured Rate (Mb/s)	Measured Rate (%)	Measured Rate (Frames/s)
76	1	1700.0	4.1	0.24	4802
76	2	1700.0	8.3	0.49	9604
76	4	1700.0	16.7	0.98	19208
76	8	1700.0	33.1	1.95	38416
76	16	1700.0	66.3	3.90	76832
76	32	1700.0	132.8	7.81	153664
76	64	1700.0	265.5	15.62	307328
76	96	1700.0	398.3	23.43	460911
76	128	1700.0	531.1	31.24	614610
76	160	1700.0	663.7	39.04	768176
76	192	1700.0	796.5	46.85	921833
76	224	1700.0	928.2	54.60	1074402
76	256	1700.0	1060.8	62.40	1227849
76	288	1700.0	1193.4	70.20	1381315
76	320	1700.0	1326.0	78.00	1534774
76	352	1700.0	1458.6	85.80	1688229
76	375	1700.0	1554.0	91.41	1798528

# OTN

The goal of the OTN, or digital wrapper technology, is to combine and accelerate the benefits of SONET/SDH with the bandwidth expandability of dense wavelength division multiplexing (DWDM). OTN applies the operations, administration, maintenance, and provisioning (OAM&P) functionality of SONET/SDH, which allows for protocol transparency; optimized, error-free transmission; and reduces the number of Reamplify–Reshape–Retime (3R) regeneration points in an optical network. This enables operators to cost-effectively install, maintain, and scale their next-generation networks. Figure 8 provides a view of the OTN frame.

## Support OTU-1 (2.7 G) and OTU-2 (10.7, 11.05, 11.1 Gb/s) Optical Interfaces

- Test end-to-end connectivity by transmitting and receiving OTN (Reed Solomon [RS], 255/239) signals including a variety of client signals and pseudorandom bit sequence (PRBS) test patterns
- Save time by simultaneously and independently testing 11.1, 11.05, 10.7, and 2.7 Gb/s interfaces
- Emulate 10 GigE client within 11.1 and 11.05 Gb/s OTN interface
- Perform SONET BER testing within 2.7 and 10.7 Gb/s OTN interface

## Analyze and Generate OTU, ODU and OPU Overhead, Errors, and Alarms

- Insert and analyze a variety of errors and alarms in network troubleshooting and equipment verification applications
- Test the fault type fault location (FTFL), section, and path monitoring functions
- Ensure that signal degradation and fail thresholds on NEs and management systems are triggered appropriately
- Verify NE interoperability with the tandem connection monitoring (TCM) bytes

## Transmit and Analyze Correctable and Uncorrectable FEC Errors

- Verify the ability of a NE to correct conditions through the use of forward error correction (FEC)-enabled signals

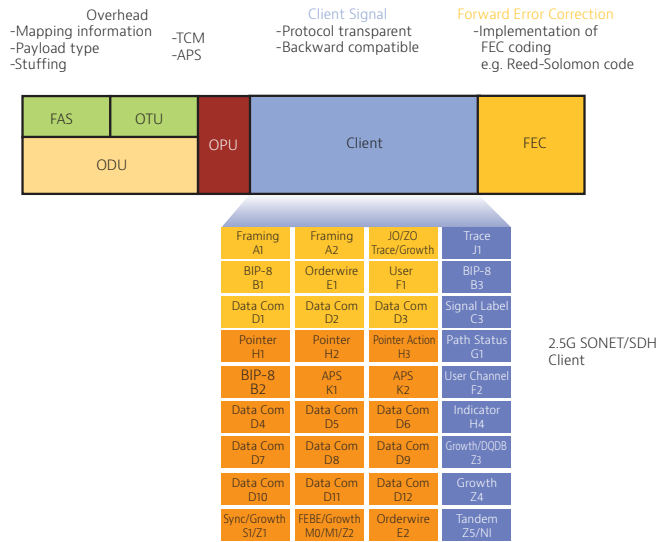
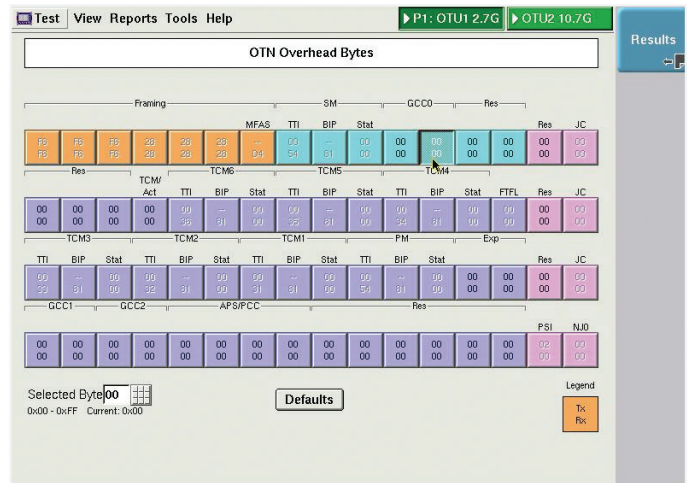

Figure 8. OTN Frame



OTN overhead byte manipulation



## SONET/SDH

### 1.5 M to 10 G SONET/SDH BER Testing

The Transport Module performs BER testing on all line interfaces in end-to-end or loopback applications, inserts errors and alarms to verify NE conformance and connectivity, and measures BERs to ensure QoS.

### SONET/SDH Overhead Byte Manipulation and Analysis

Using the overhead byte manipulation and analysis capability of the Transport Module, users can modify K1 and K2 bytes to test automatic protection switching (APS) to specify and identify user-configurable path trace messages and payloads.

### Service Disruption Measurements

The Transport Module measures the protection switch times of SONET/SDH rings and their effects on tributaries. By measuring various error and alarm conditions on the tributaries, providers can verify that their transport network is providing adequate redundancy to guarantee SLAs, as Figure 9 shows.

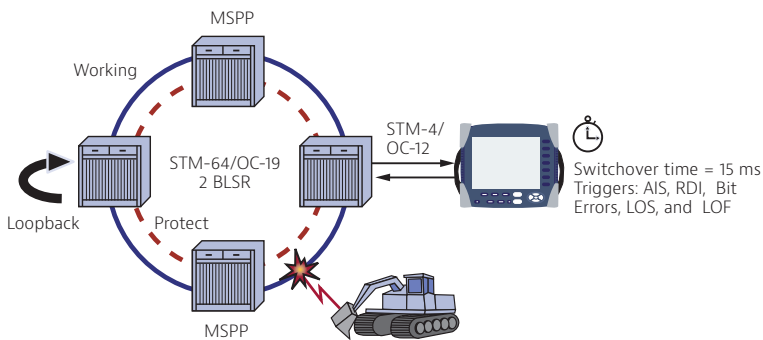

Figure 9. Service Disruption

## Jitter and Wander

As legacy and IP-based networks continue to converge, providers are seeing deployments of new technologies, such as TDM over IP. These service offerings are creating new testing needs that combine traditional jitter/wander and packet-based testing for QoS. In addition, the emergence of low-cost SFP optics has increased the need to verify optical jitter performance before service deployment. Based on established market leadership and design of the jitter functionality found in the Viavi ANT and ONT product families, the flexibility of the Transport Module allows users to combine both legacy and emerging test needs in support of today's services and network architectures.

### O.172 / O.173 Compliant Jitter and Wander Testing

- Support T1, E1, T3, E3, E4, STS-1, STM-1e, 155 M, 622 M, 2.5 G, and 2.7 G SONET/SDH, OTN jitter and wander generation, and analysis
- For optical interfaces, support 35 mUI accuracy for jitter measurements

### Ensure SONET/SDH Network Timing and Synchronization

One of the most common SONET/SDH problems continues to be the synchronization of timing. If the timing of a NE or system is allowed to drift even slightly, it can have devastating effects on the network. The Transport Module jitter and wander test capability verifies the correct timing of NEs, systems, and services.

## Verify Jitter Transfer, Maximum Tolerable Jitter, and Intrinsic Jitter Performance

Users may verify system and NE performance using the Transport Module's Automatic Measurement Sequences with stored and user-definable jitter masks. Ensuring that NE and system performance pass jitter transfer (JTF), maximum tolerable jitter (MTJ), and intrinsic jitter metrics, as Figure 10 illustrates.

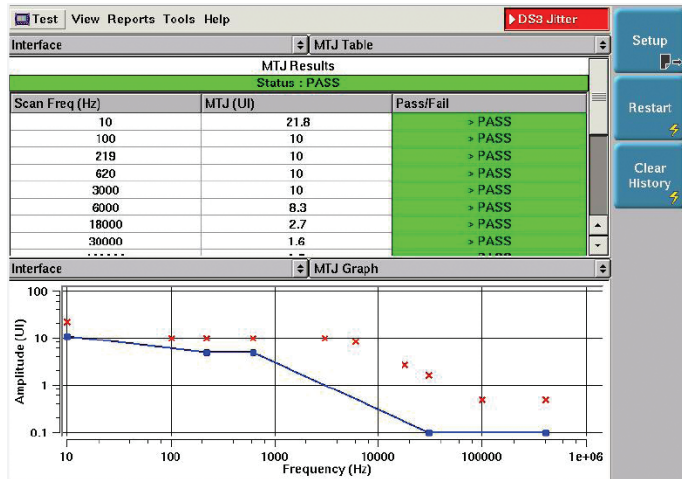

MTJ results

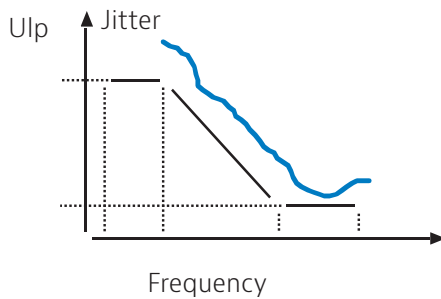

Figure 10 Jitter mask

## NewGen (Ethernet over SONET/SDH)

The NewGen module provides support for the efficient delivery of Ethernet services over the legacy SONET/SDH network, Figure 11 shows. Test functionality includes:

- Support of optical 155 M, 622 M, 2.5 G SDH, and SONET interfaces
- Higher- and lower-order virtual concatenation (VCAT) with up to 1 G Ethernet traffic
- VCAT Group search for lower-order traffic
- Framed Generic Framing Protocol (GFP-F) generation and analysis
- Differential delay analysis
- Link Capacity Adjustment Scheme (LCAS) generation and analysis including protocol tracer
- Support of different Ethernet frames, such as DIX and 802.3
- Virtual local area network (VLAN) and Q-in-Q generation and filter capability

This testing functionality from the interface to the Ethernet analysis level is combined in a single, stand-alone unit making it the perfect tool for installing and troubleshooting circuits transporting Ethernet over SONET/SDH.

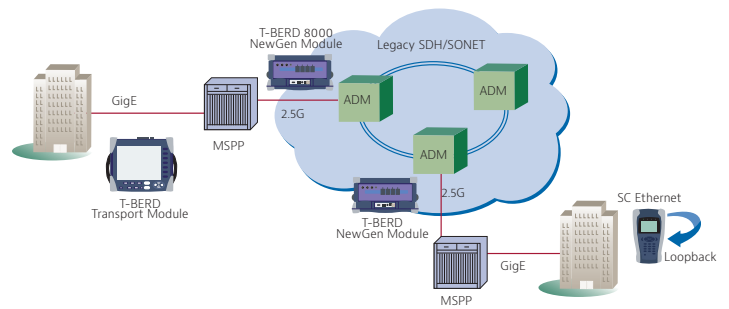

Figure 11. NewGen application

## 40 G Transport

The 40 G Transport Module addresses all 1.5 Mb/s to 40 Gb/s fiber characterization, service verification, and troubleshooting needs. The unit provides ITU-T and GR-253-compliant optics with optical power measurement and frequency offset adjustment and measurement, multiple mappings to structure for 40 Gb/s, overhead generation and analysis, extensive error and alarm generation and analysis, various timing modes, RTD measurements, and performance according to G.826 and G.828. The test functionality of the 40 G Transport Module is listed below.

### 40 G SONET/SDH BER Testing

The Transport Module performs BER testing on all line interfaces in end-to-end or loopback applications, inserts errors and alarms to verify NE conformance and connectivity, and measures BERs to ensure QoS.

### SONET/SDH Overhead Byte Manipulation and Analysis

Overhead byte manipulation and analysis permits the modification of K1 and K2 bytes to test APS, as well as supports alarm insertion, pointer increments and decrements, and user-configurable path trace messages and payloads.

### SONET/SDH Service Disruption Measurements

The Transport Module measures the protection switch times of SONET/SDH rings and their effects on tributaries. Measuring various error and alarm conditions on the tributaries let providers verify that their transport network is providing adequate redundancy to guarantee SLAs.

### Support OTU-3 (43 G) Optical Interfaces

Test end-to-end connectivity by transmitting and receiving OTN (RS, 255/239) signals, including a variety of client signals and PRBS test patterns.

### Transmit and Analyze Correctable and Uncorrectable OTN FEC Errors

Verify the ability of a NE to correct conditions through the use of FEC-enabled signals.



## Physical Characteristics

### Port Bank #2

- Includes 2.5 Gb/s, 622 Mb/s, and 155 Mb/s SONET/SDH Tx/Rx; GigE Tx/Rx and FC (1/2/4 G) Tx/Rx at 850,1310, and 1550 nm; and 10/100/1000 Mb/s Ethernet

### Port Bank #1

- Includes 2.7 Gb/s OTU-1; 2.5 Gb/s, 622 Mb/s, and 155 Mb/s SONET/SDH Tx/Rx; GigE Tx/Rx and FC (1/2/4 G) Tx/Rx at 850, 1310, and 1550 nm; and 10/100/1000 Mb/s Ethernet

### 10 Gb/s Port Bank

- 11.1, 11.05, 10.7 Gb/s OTU-2; 10 Gb/s SONET/SDH; 10 G FC; and 10 GigE LAN/WAN PHY at 850, 1310, and 1550 nm

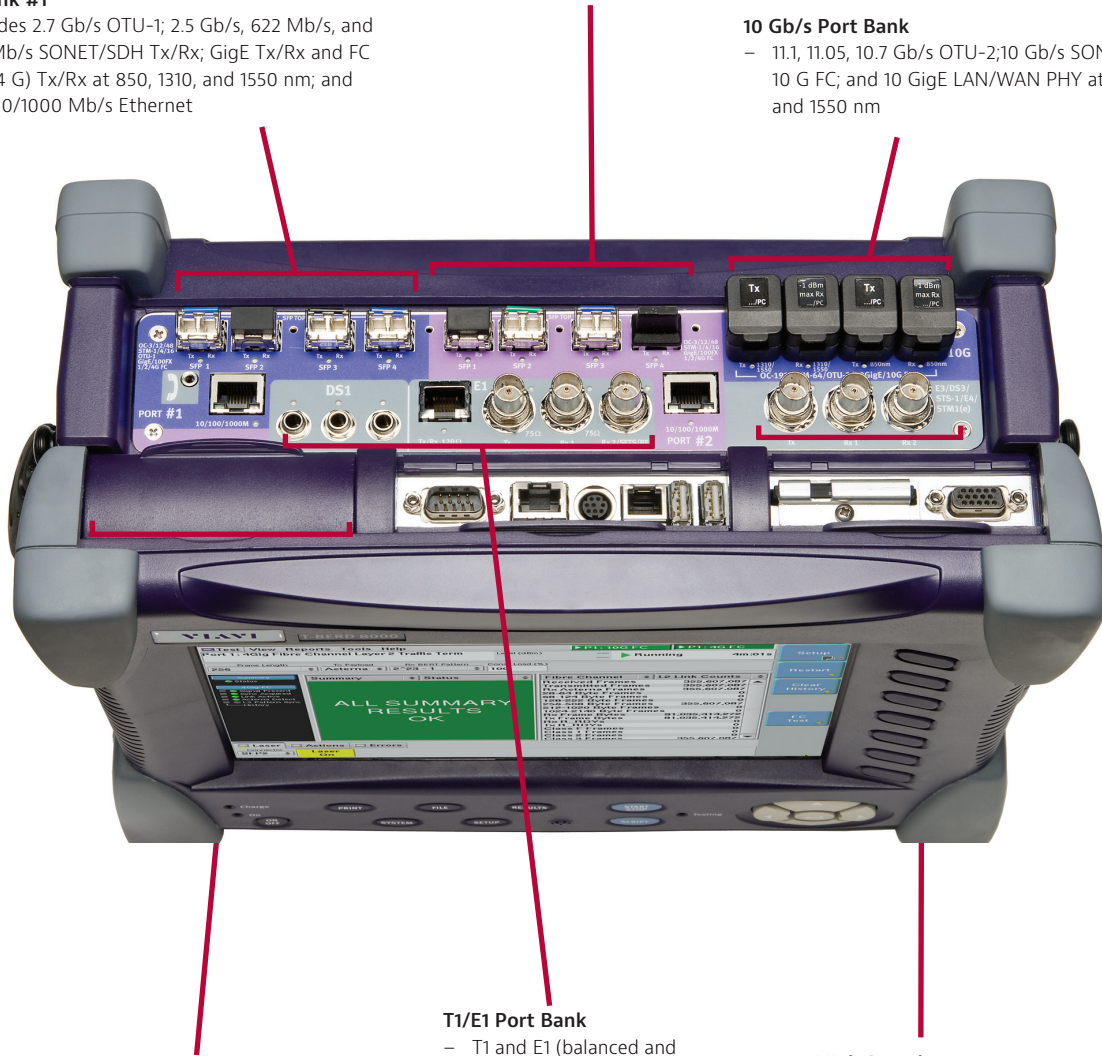

### Optical Connection Check Interfaces

- High accuracy Power Meter
- Continuous Wave Power Source
- Visual Fault Locator

### T1/E1 Port Bank

- T1 and E1 (balanced and unbalanced Tx/Rx)

### High Speed

#### Electrical Port Bank

- E3, DS3, STS-1, E4, and STM-1 (e) Tx/Rx BNCs



Contact Us **+1 844 GO VIAVI**  
(+1 844 468 4284)

To reach the Viavi office nearest you,  
visit [viavisolutions.com/contacts](http://viavisolutions.com/contacts).

© 2015 Viavi Solutions Inc.  
Product specifications and descriptions in this  
document are subject to change without notice.  
tbmts8000-ds-tfs-tm-ae  
30162514 900 0209