

## Product Overview

---

# 43961A

---

Option 010 adds the impedance measurement function to the 4396B. By installing this option into the 4396B spectrum/network/impedance analyzer, you can measure impedance parameters directly.

The 4396B with option 010 has the following added features:

- Directly displays the impedance measurement parameters.

Measurement Parameters:  $|Z|$ ,  $\theta_z$ , R, X,  $|Y|$ ,  $\theta_y$ , G, B,  $|\Gamma|$ ,  $\theta_\gamma$ ,  $\Gamma_x$ ,  $\Gamma_y$ , Cp, Cs, Lp, Ls, Rp, Rs, D, Q

- Uses I-V method to measure impedance.

Option 010 provides impedance measurements up to 1.8 GHz (a frequency range that was previously dominated by the reflection method using the network analyzer). The reflection coefficient method has difficulty measuring impedances that vary greatly from 50  $\Omega$ . However, the I-V (current and voltage) method can measure impedance equally well over a broad band impedance range.

- Provides OPEN/SHORT/LOAD fixture compensation and the port extension that eliminates additional errors by the fixture.

- External DC bias

The 4396B and 43961A themselves do not have a function that applies DC voltage. However, you can apply DC bias by using an external power supply. The 43961A provides the external DC bias connector for this purpose.

- Equivalent Circuit Analysis

There are 5 types of the equivalent circuit functions available. You can obtain the equivalent circuit parameters from the measured trace.

## 43961A Impedance Test Kit

The 43961A Impedance Test Kit is an impedance measurement accessory used by the 4396B.

### Contents

Table 1-1 shows the contents of the 43961A Impedance Test Kit.

**Table 1-1. Contents of the 43961A**

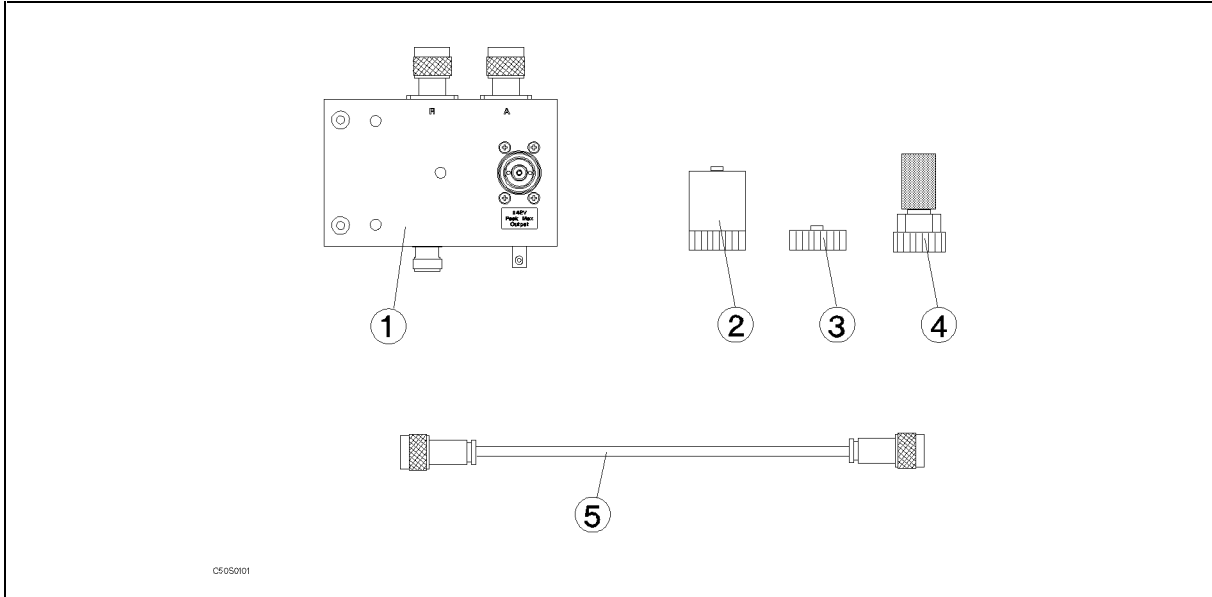

No.	Description	Qty.	Agilent Part Number
1	Impedance Test Adapter	1	43961-61001
2	0 S Calibration Standard	1	04191-85302
3	0 $\Omega$ Calibration Standard	1	04191-85300
4	50 $\Omega$ Calibration Standard	1	04191-85301
5	N(m)-N(m) cable	1	41951-61602
	Carrying Case <sup>1</sup>	1	43961-60001
	Notice <sup>1</sup>	1	43961-90000

<sup>1</sup> This part is not shown in above.

### Dimension

Figure 1-1 shows the dimension of the 43961A.

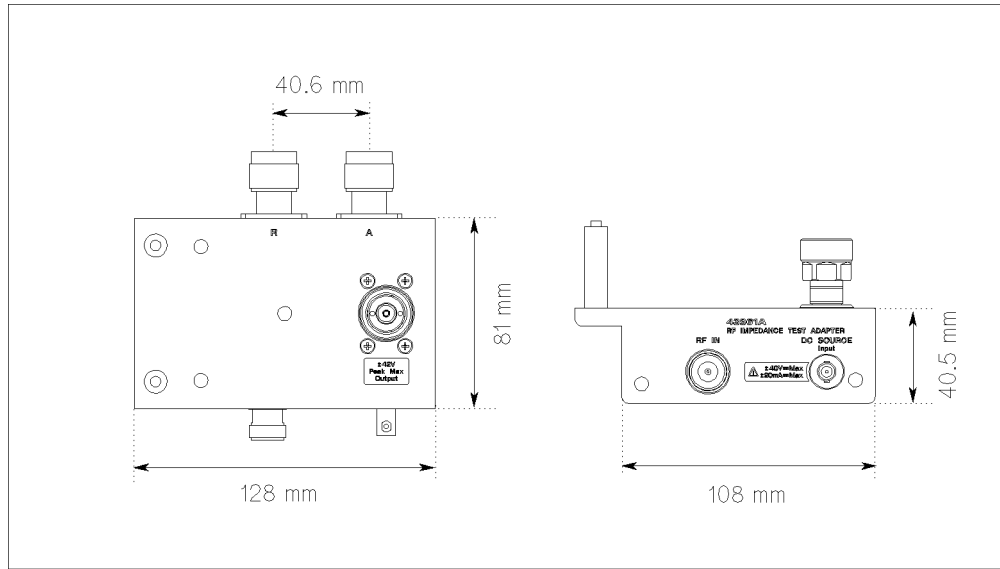

05050102

**Figure 1-1. Dimension of the 43961A**

---

## **Available Accessories**

### **16191A Side electrode SMD test fixture**

The 16191A is used to measure a side electrodes surface mount device (SMD) with high repeatability. The usable operating frequency is up to 2 GHz.

### **16192A Parallel electrode SMD test fixture**

The 16192A is used to measure a parallel electrodes surface mount device (SMD) with high repeatability. The usable operating frequency is up to 2 GHz.

### **16193A Small side electrode SMD test fixture**

The 16193A is used to measure a small, side electrodes surface mount device (SMD) with high repeatability. The usable operating frequency is up to 2 GHz.

### **16194A High temperature component fixture**

The 16194A is used to measure a component in wide temperature range. The operating temperature range is from  $-55^{\circ}\text{C}$  through  $200^{\circ}\text{C}$ . The usable operating frequency is up to 2 GHz.

### **16091A Coaxial termination fixture set**

The 16091A is suited to the measurement of lead-less material samples or small size, axial lead components whose leads can be shortened. Two types of fixtures are included in the fixture set to provide flexibility for various sample sizes. The usable operating frequency is up to 1 GHz.

### **16092A Spring clip test fixture**

The 16092A provides a convenient capability for easily connecting and disconnecting samples. It has a usable operating frequency up to 500 MHz.

### **16093A/B Binding post test fixtures**

The 16093A/B are suited for the measurement of relatively large size, axial and radial lead components or devices that do not fit other fixtures. The 16093A is provided with two small binding post measurement terminals set at 7 mm intervals. The usable frequency operating of the 16093A is up to 250 MHz. The 16093B employs a common type three binding post terminal arrangement that includes an extra guard post terminal. The terminal interval is 15 mm. The usable frequency operating of the 16093B is below 125 MHz.

### **16094A Probe test fixture**

The 16094A provides probing capability for measuring circuit impedance and components mounted on circuit assemblies. The usable frequency operating of the 16094A is below 125 MHz.

---

## I-V Measurement Method

The 4396B, when combined with the 43961A, uses an I-V measurement method to measure the impedance of a DUT. This section describes this measurement method.

### Basic Concept of I-V Method

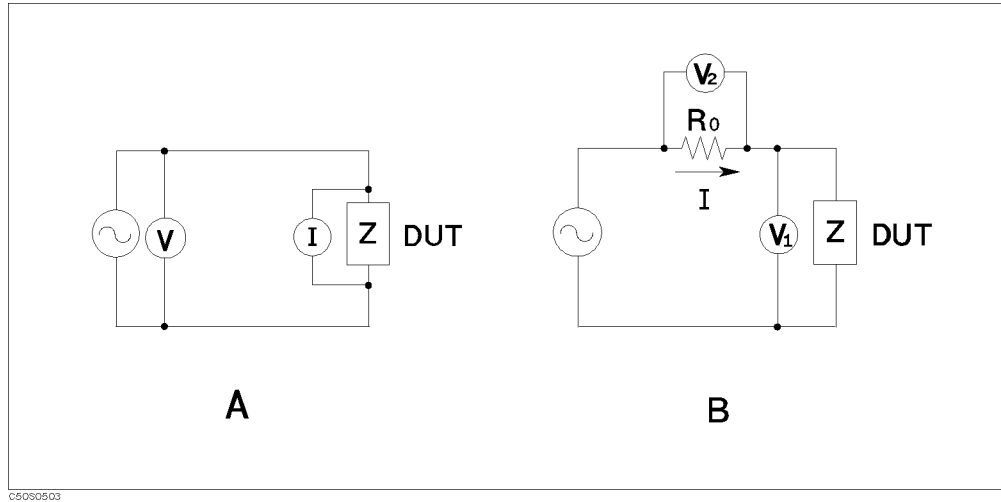

Figure 5-1. I-V Measurement Method

The unknown impedance,  $Z$ , can be calculated from the measured voltage and current using Ohm's law: (See circuit A in Figure 5-1.)

$$Z = \frac{V}{I}$$

The current,  $I$ , can be also obtained by the voltage level of the known resistance,  $R_0$ .

$$Z = \frac{V_1}{I} = \frac{V_1}{V_2} R_0$$

See circuit B in Figure 5-1.

The 4396B uses circuit B to determine the unknown impedance.

### How This Is Different From Impedance Conversion in the Network Analyzer Mode

The network analyzer part of the 4396B has an impedance conversion feature that converts the reflection coefficient to impedance. The reflection is determined by the impedance of the DUT.

$$Z = R_0 \frac{1 - \Gamma}{1 + \Gamma} \quad (-1 \leq \Gamma \leq 1)$$

If the DUT impedance is equal to the characteristic impedance, there is no reflection. When the impedance is an infinite value like OPEN, the all input signal is reflected. This means, the reflection signal level covers all impedance range (50 to infinite) by the output level. Thus, the reflected signal level difference is very small when compared to the impedance difference in the higher impedance ranges.

When the impedance is greater than characteristic impedance, the measurement error is increased. For example, for an impedance of 2 k $\Omega$ , a 1 percent error in the reflection coefficient is converted to a 24 percent error in impedance.

However, with the I-V method, the measurement error does not depend on the impedance of the DUT because the I-V method measures the impedance directly from the ratio of the voltage and current. Using the I-V method, you can measure a wide range impedance with constant accuracy. This is the major advantage of the I-V method.

---

## 4396B Option 010 Specifications

### Measurement Functions

Measurement parameters      Z, Y, L, C, Q, R, X, G, B,  $\theta$

Display parameters             $|Z|, \theta_z, R, X, |Y|, \theta_y, G, B, |\Gamma|, \theta_\gamma, \Gamma_x, \Gamma_y, C_p, C_s, L_p, L_s, R_p, R_s, D, Q$

### Display Formats

- Vertical lin/log scale
- Complex plane
- Polar/Smith/admittance chart

### Sweep Parameters

- Linear frequency sweep
- Logarithmic frequency sweep
- List frequency sweep
- Linear power sweep (dBm)

### IF Bandwidth

10, 30, 100, 300, 1k, 3k, 10k, 40k [Hz]

### Calibration

- OPEN/SHORT/LOAD 3 term calibration
- Fixture compensation
- Port extention correction

### Unknown Port

- APC-7 connector

### Output Characteristics

Frequency range ..... 100 kHz to 1.8 GHz

Frequency resolution ..... 1 mHz

Output Level ..... -60 to +20 dBm (@RF OUT port)

Note: Signal level at the measurement port is 6 dB lower than the RF OUT port when the measurement port is terminated by 50  $\Omega$ .

Output level accuracy .....  $A + B + 6$  [dB]  $\times F / (1.8 \times 10^9)$

Where,

$$A = 2 \text{ dB } (\pm 5^\circ\text{C})$$

$$B = 0 \text{ dB } ( \text{OSC} \leq 0 \text{ dBm } ), \text{ or } 1 \text{ dB } ( -40 \leq \text{OSC} < 0 \text{ dBm } ), \text{ or } 2 \text{ dB } ( -60 \leq \text{OSC} < -40 \text{ dBm } )$$

$F$  is output frequency.

Output level resolution .....	0.1 dB
Measurement port impedance .....	Nominal 50 $\Omega$

### External DC Bias Input

Maximum voltage .....	$\pm 40$ V
Maximum current .....	20 mA

\* 2 k $\Omega$   $\pm$  5% resistor is inserted for DC bias current limitation.

---

## Measurement Basic Accuracy (Supplemental Performance Characteristics)

Measurement accuracy is specified at the connecting surface of the APC-7 connector of the 43961A under the following conditions:

Warm up time .....	> 30 minutes
Ambient Temperature .....	23 °C $\pm$ 5°C (@same temperature at which calibration was performed.)
Signal level (@ 50 $\Omega$ Terminated) .....	-6 to 14 dBm
Correction .....	ON
IFBW .....	$\leq$ 300 Hz
Averaging (cal) .....	$\geq$ 8



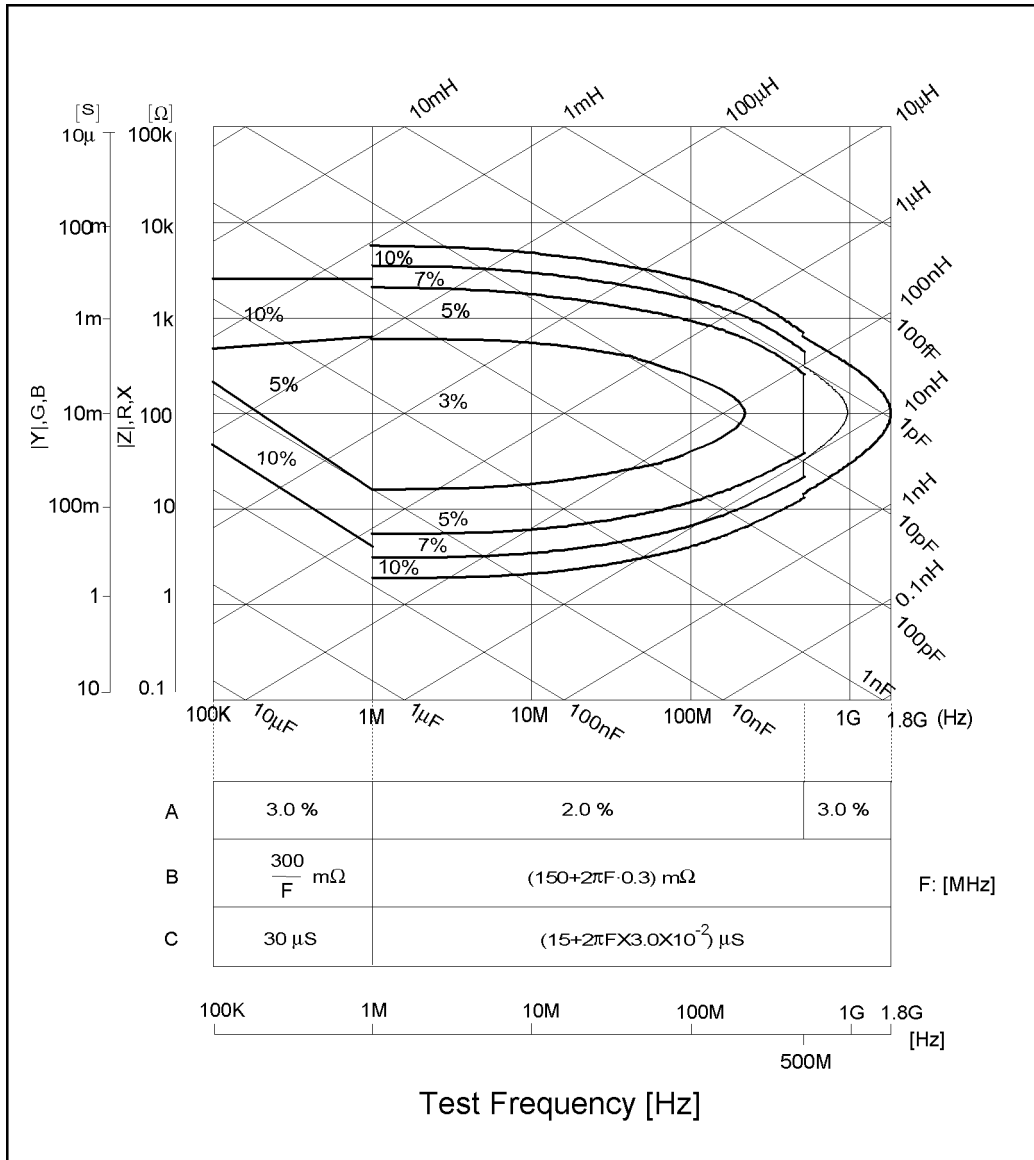

C5606001

**Figure 10-9. Impedance Measurement Accuracy**

**|Z| -  $\theta$  Accuracy**

|Z| accuracy

$$Z_a = A + (B/|Z_m| + C \times |Z_m|) \times 100 [\%]$$

$\theta$  accuracy

$$\theta_a = \sin^{-1}(Z_a/100)$$

Where,  $|Z_m|$  is  $|Z|$  measured. A, B, and C are obtained from Figure 10-9.

### **|Y| - $\theta$ Accuracy**

|Y| accuracy  $Y_a = A + (B \times |Y_m| + C/|Y_m|) \times 100$  [%]

$\theta$  accuracy  $\theta_a = \sin^{-1}(Y_a/100)$

Where,  $|Y_m|$  is |Y| measured. A, B, and C are obtained from Figure 10-9.

### **R - X Accuracy (Depands on D)**

Accuracy	$D \leq 0.2$	$0.2 < D \leq 5$	$5 < D$
$R_a$	$\pm X_m \times X_a/100$ [ $\Omega$ ]	$R_a/\cos\theta$ [%]	$R_a$ [%]
$X_a$	$X_a$ [%]	$X_a/\sin\theta$ [%]	$\pm R_m \times R_a/100$ [ $\Omega$ ]

Where,

D can be calculated as:  $R/X$ , or  
 $R/(2\pi f \times L_s)$ , or  
 $R \times 2\pi f \times C_s$

$\theta$  can be calculated as:  $\tan^{-1}(X/R)$ , or  
 $\tan^{-1}(2\pi f \times L_s/R)$ , or  
 $\tan^{-1}(1/(R \times 2\pi f \times C_s))$

$R_a = A + (B/|R_m| + C \times |R_m|) \times 100$  [%]

$X_a = A + (B/|X_m| + C \times |X_m|) \times 100$  [%]

$R_m$  and  $X_m$  are the measured R and X, respectively. A, B, and C are obtained from Figure 10-9.

### **G - B Accuracy (Depands on D)**

Accuracy	$D \leq 0.2$	$0.2 < D \leq 5$	$5 < D$
$G_a$	$\pm B_m \times B_a/100$ [S]	$G_a/\cos\theta$ [%]	$G_a$ [%]
$B_a$	$B_a$ [%]	$B_a/\sin\theta$ [%]	$\pm G_m \times G_a/100$ [S]

Where,

D can be calculated as:  $G/B$ , or  
 $G/(2\pi f \times C_p)$ , or  
 $G \times 2\pi f \times L_p$

$\theta$  can be calculated as:  $\tan^{-1}(B/G)$ , or  
 $\tan^{-1}(2\pi f \times C_p/G)$ , or  
 $\tan^{-1}(1/(G \times 2\pi f \times L_p))$

$G_a = A + (B/|G_m| + C \times |G_m|) \times 100$  [%]

$B_a = A + (B/|B_m| + C \times |B_m|) \times 100$  [%]

$G_m$  and  $B_m$  are the measured  $G$  and  $B$ , respectively. A, B, and C are obtained from Figure 10-9.

### D Accuracy

Accuracy	$D \leq 0.2$	$0.2 < D$
$D_a$	$Z_a/100$	$(Z_a/100) \times (1 + D^2)$

Where,  $Z_a$  is  $|Z|$  accuracy.

### L Accuracy (Depends on D)

Accuracy	$D \leq 0.2$	$0.2 < D$
$L_a$	$L_a/100$	$L_a(1 + D)$

Where,  $L_a = A + (B/|Z_l| + C \times |Z_l|) \times 100$  [%]

$|Z_l| = 2\pi f \times L_m$ ,  $f$  is frequency in Hz, and  $L_m$  is measured L. A, B, and C are obtained from Figure 10-9.

### C Accuracy (Depends on D)

Accuracy	$D \leq 0.2$	$0.2 < D$
$C_a$	$C_a$	$C_a(1 + D)$

Where,  $C_a = A + (B/|Z_c| + C \times |Z_c|) \times 100$  [%]

$|Z_c| = 2\pi f \times C_m$ ,  $f$  is frequency in Hz, and  $C_m$  is measured C. A, B, and C are obtained from Figure 10-9.