

Agilent N3900A N3914AL 3909AR Specs

Provided by www.AAATesters.com

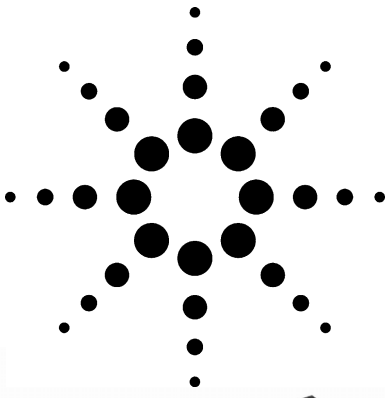

Agilent N3900A **Modular Network Tester Mainframe**

Agilent N3910AM, N3910AL, N3911AL, N3914AL **OTDR Test Engines**

Agilent N3916AL **Chromatic Dispersion (CD) Analyzer/OTDR Test Engine**

Agilent N3909A **Polarization Mode Dispersion (PMD) Analyzer Test Engine**

Agilent N3935A **Optical Spectrum Analyzer (OSA) Test Engine**

Agilent N3940AA **1x12 Optical Switch Module**

Agilent N3988A **USB Video Microscope Camera**

Data Sheet

It's about network testing. It's about you.
The Perfect Fit.



Agilent Technologies

Contents

Features, Benefits and Specifications

Modular Network Tester Mainframe	3
OTDRs	7
1x12 Optical Switch Module	11
Chromatic Dispersion (CD) Analyzer Test Engine.....	13
Polarization Mode Dispersion (PMD) Analyzer Test Engine.....	15
Optical Spectrum Analyzer (OSA) Test Engine.....	17
USB Video Microscope Camera	20

Ordering Information

Modular Network Tester Mainframe	22
OTDR Test Engines	22
1x12 Optical Switch Module	23
Chromatic Dispersion (CD) Analyzer/OTDR Test Engine	24
Polarization Mode Dispersion (PMD) Analyzer Test Engine.....	24
Optical Spectrum Analyzer (OSA) Test Engine.....	25
USB Video Microscope Camera	25
System Options and Accessories.....	26

Related literature and further information.....	27
---	----

Safety Information	27
--------------------------	----

Support, Services, and Assistance.....	28
--	----

Specifications describe the instrument's warranted performance, measured with typical PC-type connectors. Characteristics and typical data provide information about the non-warranted instrument performance.

Agilent test equipment is produced to the ISO 9001 international quality system standard as part of Agilent's commitment to continually increasing customer satisfaction through improved quality control.

Modular Network Tester Mainframe

Agilent N3900A

Description The Agilent N3900A Modular Network Tester is a portable, lightweight, rugged test platform for the installation, commissioning and maintenance of optical networks. Developed from customer feedback from installation and maintenance (I&M) technicians worldwide, its modular design delivers the measurements you need, when you need them. Snap-on measurement modules meet your test requirements for today's communications networks; the modular platform protects your investment, and lets you grow into your future measurement needs.

The Modular Network Tester can hold up to three modules to perform OTDR measurements, chromatic dispersion, polarization mode dispersion or optical spectrum analysis, or a 1x12 Optical Switch module. A video microscope camera can be connected to ensure clean, fast and safe connector inspection as the connector surface picture can be analyzed on the 10.4" display. From the carrying case to the handles and tilt-stand, from the pop-up connector to your choice of interface, attention to detail and to your feedback provide the perfect fit for the way you work.



The Agilent Modular Network Tester

Features and Benefits

Processing power The Modular Network Tester is powered by a 64Bit RISC[®] processor architecture with a real-time operating system, VXWorks[®], for mission critical operations. Each test engine has its own RISC processing power for ultra fast data acquisition and high accuracy post processing. The Modular Network Tester boots in one minute and all the modules can be hot-swapped – so it's always ready to work when you are.

Ergonomic design The Modular Network Tester feels like an extension to your arm. It has a hand strap, an ergo grip, and a shoulder strap to work with you and keep your hands free.

Attaching a fiber optic connector to a test engine has never been so safe and fast. The pop-up connector can be raised for connection and cleaning purposes and sits securely in the down position, protected by a dust cover while in transit.

The video microscope protects your eyes and speeds up your fiber optic connector cleaning procedures. Flash-card data storage is rugged and secure – there is no internal hard drive to crash. The Toolkit companion software, Toolkit III, prepares acceptance reports the way your customers want them and handles post-processing jobs to free you up for the next task.

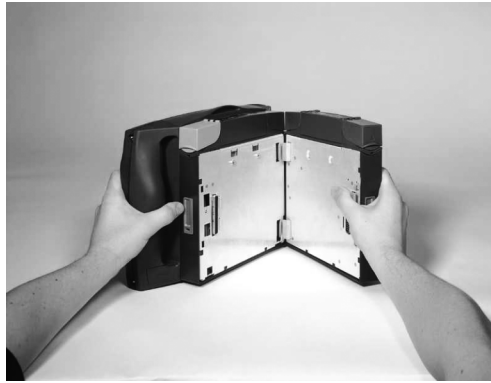

True hot-swappable modularity in a rugged field portable device

The user interface fits you and your work

The Modular Network Tester mainframe has a large and brilliant 10.4" color display for indoor and outdoor application with touch screen functionality and cursor control. If you prefer soft keys you have the choice; minimum button pushing allows you to execute your task fast. A consistent user interface throughout all applications gets your job done quickly, as well as making it fast and easy to learn. Context-sensitive help is always available at the touch of a button.

Different users can store their profile settings to optimize working conditions when the equipment is shared between technicians.



Freedom of choice: Either a touch screen or soft keys to navigate

Connect to your IT world

USB & LAN ports connect the Modular Network Tester to your PC, making it a part of your IT network, for remote control using the E6092A Toolkit software, or for uploading software updates or upgrades. An RS232 interface is also available. All popular printers are supported via the parallel port.

Secure and rugged data storage

Measurement data can be stored safely in the rugged internal memory, on a floppy disc or on PCMCIA CompactFlash® cards with up to 512MB of memory.

Long operating time

The unit is operated with an intelligent battery and has a built in battery charger. Under normal operating conditions with one OTDR test engine attached, the Modular Network Tester will operate for a full working day. The intelligent battery (Lilon) displays the current charge level and the time left for completing the task. A discharged battery can be exchanged in seconds.

Training

If classroom based training is needed, you can connect an LCD projector to the VGA output of the Modular Network Tester and project the display on a large screen. If you need additional training material, please contact your Agilent representative.

Common Features and Benefits of Modular Network Tester Modules and Test Engines

Pop-up connector for easy access and reliable protection

The optical fiber connector is a critical component of fiber optic test products. During transit it should be well protected; however, it should be easy to access during operation. With the unique pop-up connector, Agilent provides the ideal solution to both problems.

In transit, the connector port is pushed down into the test engine housing and is kept protected and clean by a dust cover.

For fiber connection and cleaning purposes, the connector is easily released and slides gently to the up position. The connector is visible from the front of the instrument and the user is able to connect the fiber quickly and easily, without and obstacles. This also minimizes the risk of scratches to the connector.



Connector in up position



Connector in down position

Universal connector interface

With Agilent's universal connector interface, a large range of standard fiber optic connectors can be connected to the test engine or module. Technicians and engineers can easily attach the needed connector interface, even when working on site. When the connector interface is removed, the fiber ferrule is easily accessible for a simple cleaning process.

Specifications: Modular Network Tester Mainframe

Storage **Internal Memory:** 170 MB available memory
3.5" floppy disk drive: for high density, 720/1440 KB floppy disks. MS-DOS format compatible.

PCMCIA One Type III or two Type II PC Card slots
Flash Disk: up to 512 MB

Display **SVGA-LCD:** 25.9 cm (10.4") color TFT display
800 x 600 pixels (SVGA)

Human interface

- Touch screen^a
- Cursor control navigation^a
- 5 User programmable Soft keys
- On/Off key
- Help key
- Measurement Stop/Start key
- Power On indicator
- Battery charging indicator
- Battery charging level

Interfaces **Universal Serial Bus (USB 1.1):** for connection with USB Video Microscope Camera N3988A

USB 1.1 Peripheral: Transmission for up to 12 Mbit/s
RS232C: 9-pin, maximum baud rate 115200 baud.
Parallel Port: 25-pin, standard parallel port (Centronics)
LAN: RJ-45 jack, (Ethernet 10/100)
Keyboard: PS/2 port (Mini-DIN) for English Standard, PS/2 or AT keyboard
VGA: Analog monitor output with SVGA resolution, 60 Hz^b
Headset: Standard microphone and speaker plug^c

General **Operating temperature:** 0 °C to +50 °C
Storage temperature: -20 °C to +60 °C (without battery)
Humidity: 95% Relative humidity from 0 °C to +40 °C
Dimensions: 230 mm H, 330 mm W, 61 mm D (9.0" x 13" x 2.4")
Weight: net 3.3 kg (7.5 lbs), including battery pack.

Power supply **AC:** 100 – 240 V_{rms} ± 10% 50 – 60 Hz.
DC: 18 V, 60 W
Battery: Lilon
Battery operating time: typically 5 hours continuous measurements with standard OTDR test engine at 50% backlight setting.
Charging Time: < 3 hours non-operating
Battery deep discharge protection: provided

[a] Touch screen can be disabled, but full control is possible with cursor navigation

[b] Adapter to connect to standard VGA interface provided with N3900A Modular Network Tester

[c] For availability of a free upgrade please contact your Agilent representative.

OTDRs

Agilent N3910AM, N3910AL, N3911AL, N3914AL, N3916AL

Description The Agilent OTDR test engines N391x work together with the Agilent Modular Network Tester, and are easy to snap on. The OTDR application is uploaded in seconds due to the dynamic software architecture, and allows plug and play operation. Each OTDR test engine has built-in RISC processing power for fast and accurate trace acquisition and data processing. These test engines work in parallel processing mode with other connected test engines, for example, the 1x12 Switch module. All OTDR test engines can be shared between multiple users, without the need for any software changes.



OTDR Test

Features and Benefits

Save time. Make money. With the N3910AL (1310/1550 nm), and N3911AL (1550/1625 nm) OTDR test engines, long haul fiber links can be tested and qualified faster than ever before, thanks to their 45 dB ultra high dynamic range technology. For high fiber count cables, where the test time is critical, these OTDR Test engines significantly reduce test times from minutes to seconds.

One connection, 3 wavelengths: Tested all at once For metro applications, where the transmission wavelength spectrum ranges from 1310 nm to 1625 nm, Agilent offers a very high performance 3 wavelength test engine N3914AL (1310/1550/1625 nm), which tests fibers at all 3 wavelengths and automatically saves the trace files.

All done. All right. After the measurements have been taken, the Pass/Fail Test will automatically check for attenuation, insertion and return loss. The new Bending Test will locate both macro and micro bends.

Remote Control The E6092A Toolkit companion software lets you control your complete OTDR test procedure remotely, via LAN or USB, for optimal comfort and productivity.

Acceptance test done The E6092A Toolkit companion software can also prepare acceptance reports the way your customers want them and handles post-processing jobs to free you up for the next task.

Built-in applications

- OTDR Mode
- Multi Fiber Test
- Automated OTDR measurements using 1x12 Optical Switch
- Accumulated optical return loss
- Accumulated end-to-end loss
- Loop Back fiber testing mode
- Build-in continuous wave source (CW)
- Pass/Fail Test

Specifications: OTDR Test Engines

Typical values are printed in **BOLD**.

Optical Performance ^a

2λ test engines		Agilent N3910AM	Agilent N3910AL	Agilent N3911AL		
Central wavelength [nm]						
		1310	1550	1310	1550	1550 1625
Tolerance [nm]						
		± 25	± 25	± 25	± 25	± 20
Dynamic range (dB)^b						
Pulse width	10 ns	19	17	24	22	22 18
	100 ns	24	22	29	27	27 24
	1 μs	30	29	35	34	34 30
	10 μs	38	37	42	41	41 37
	20 μs	40	39	45	43	43 39
3λ test engines				Agilent N3914AL		
Central wavelength [nm]						
				1310	1550	1625
Tolerance [nm]						
				± 25	± 25	± 20
Dynamic range (dB)^b						
Pulse width	10 ns			22	20	16
	100 ns			27	25	22
	1 μs			33	31	28
	10 μs			40	38	35
	20 μs			43	41	38
4λ test engines				Agilent N3916AL		
Central wavelength [nm]						
				1310	1480	1550 1625
Tolerance [nm]						
				± 25	± 20	± 25 ± 20
Dynamic range (dB)^b						
Pulse width	10 ns			22	19	20 16
	100 ns			27	24	25 22
	1 μs			33	30	31 28
	10 μs			40	37	38 35
	20 μs			43	-	41 38

At any wavelength the following pulse widths are selectable: 10 ns, 30 ns, 100 ns, 300 ns, 1 μ s, 3 μ s, 10 μ s.
 20 μ s can be selected for any wavelength except 1480nm.
 All Agilent OTDR test engines provide a cw-source mode at the selected wavelength.

Resolution

Test Engine	All single-mode test engines
Event dead zone ^c	3 m
Attenuation dead zone ^d	10m @ 1310 nm / 12 m @ 1550 nm / 14 m @ 1625 nm

Characteristics

Distance accuracy ^e		
Offset error	Scale error	Sampling error
± 0.3 m	$\pm 5 \times 10^{-5}$	± 0.5 sampling spacing

Loss/reflectance accuracy^f

Backscatter measurements Loss Accuracy	Reflectance measurements^g Reflectance Accuracy
± 0.03 dB/dB	± 1.0 dB

Backscatter linearity^h

Backscatter Linearity 1km to 100 km
± 0.03 dB

Sampling points: up to 64000.
Minimum sample spacing: 8 cm.
Pulse width: selectable, from 10 ns to 20 μ s.

CW-Source mode:

Output power level: -3 to -8 dBm (depending on test engine type and wavelength.)
Stabilityⁱ: ± 0.1 dB (± 0.15 dB @ 1625 nm)
Modulation: 270 Hz, 1 kHz, and 2 kHz square wave.

Horizontal parameters

Start: 0 km to 400 km.
Span: 0.1 km to 400 km.
Readout resolution: 0.1 m.
Minimum sample spacing: 8 cm.
Refractive index: 1.00000 - 2.00000.
Length unit: km, ft or miles.
Measurement points: User selectable 4000 to 64000.

Vertical parameters

Vertical scale: 0.1 - 10.0 dB/Div.
Readout resolution: 0.001 dB.
Reflectance range: -14 dB to -70 dB.
Backscatter coefficient: 10 dB to 70 dB at 1 μ s.
Auto setup and analysis: provided.
Instrument settings: storage and recall of user-selectable instrument settings.

Optical Interfaces

Output connector: optional FC/PC, DIN 47256, ST, FC/APC, SC, E2000, LC, MU. All are user-exchangeable.

Scan trace

Type of events: reflective and non-reflective events.
Maximum number of events: 100.
Threshold for non-reflective events: 0.0 to 5.0 dB, selectable in 0.01 dB steps.
Threshold for reflective events: -14.0 to -65.0 dB and 0.00 dB (disabled), selectable in 0.1 dB steps.
Threshold for fiber breaks: 0.1 to 10 dB and 0.00 dB (disabled), selectable in 0.1 dB steps.

Documentation **Trace format:** Bellcore/Telcordia compliant according to GR-196-CORE Issue 2 OTDR Data Standard.
– GR 196, Revision 1.0
– GR 196, Revision 1.1
– GR 196, Revision 2.0

Trace information: five comment labels of up to 15 alphanumeric characters and five comment fields of up to 41 alphanumeric characters are provided for each trace.

General **Operating temperature:** 0 °C to +50 °C
Storage temperature: -40 °C to + 60 °C
Humidity: 95% R.H from 0 °C to + 40 °C.
Dimensions: 217 mm H, 212 mm W, 33 mm D.
(8.6" x 8.4" x 1.3")
Weight: net <1.2 kg (2.5 lbs)
Laser safety class: All laser sources specified by this data sheet are classified as Class 1M according to IEC 60825-1 (2001).
All laser sources comply with 21 CFR 1040.10 except for deviations pursuant to Laser Notice No. 50, dated 2001-July-26
Recommended recalibration period: 2 years.
Power consumption: max. 8 W
Operating Time: typically 5 hours continuous measurement time with a standard OTDR test engine snapped-on to Modular Network Tester mainframe with 50% backlight setting.

-
- [a] *Guaranteed specifications measured at 22 °C ± 3 °C. Bold values are typical specifications.*
- [b] *Measured with a standard single-mode fiber at SNR = 1 noise level and with 3 minutes averaging time. Optimize mode: dynamic.*
- [c] *Reflectance ≤ -35 dB at a pulse width of 10 ns and with a span of ≤4 km. Optimize mode: resolution.*
- [d] *Typical specification @ Reflectance ≤ -50 dB at a pulse width of 30 ns, span ≤4 km. Guaranteed specification @ Reflectance ≤ -35 dB at a pulse width of 30 ns and with a span of ≤4 km. Optimize mode: resolution.*
20m @ 1310 nm: Agilent N3910AM, N3910AL, N3911AL, and N3914AL
25m @ 1550 nm: N3910AM, N3910AL, N3911AL, N3914AL
28m @ 1625 nm: N3911AL, N3914AL
- [e] *Distance accuracy: offset error + scale error * distance + sampling error.*
- [f] *SNR ≥ 15 dB and with 1 μs, IEC Standard 61746*
- [g] *-20 dB to -60 dB at a pulse width of 100ns*
- [h] *Displayed OTDR trace and its least square approximation line, pulse width 1 μs, 1550nm, measured with 100 km special reference fiber*
- [i] *After 10 minute warm-up (15 min., T = constant).*

1x12 Optical Switch Module

Agilent N3940AA

Description The Agilent 1x12 Optical Switch Module works in conjunction with N391x OTDR test engines on the Agilent Modular Network Tester. It is easily snapped onto the Modular Network Tester behind the OTDR test engine. The 1x12 Optical Switch provides fast and accurate automated testing of cables with high fiber counts, such as ribbon fiber cables. For operation the OTDR port is connected to the input port of the switch.

The multi fiber test, which is built into the Modular Network tester, switches the OTDR port to any one of the 12 output ports on the switch, enabling up to 12 fibers to be tested and qualified in a row. The results are saved automatically. Each fiber can be programmed with eight different settings, including wavelength, pulse width, range and averaging time. If you prefer not to use the automatic operation, you can also control the switch module manually through the Modular Network Tester.



Proven productivity with the 1x12 optical switch

Features and Benefits

Ribbon fiber support Bare ribbon fibers can be connected via the ribbon fiber pigtail N3989AA to the MPO port. The MPO output connector also has a moveable connector receptacle to allow easy access to the MT ferrule, therefore making sure it's simple for you to maintain optimum cleanliness of the ribbon fiber connection. With tools that are used every single day it is inevitable that a connector will get scratched at some time. In the event of a scratched connector, the internal user-replaceable ribbon fiber patch cord can be used to replace the damaged connector interface on the spot so you can continue working.

- Features** Fast, automated fiber batch testing supported by:
- Multi Fiber Test application
 - User selection of 1 to 12 fibers to be tested
 - Ribbon fiber testing support
 - Snap-On switch module ready to go in seconds
 - Innovative and first MPO connector for ribbon fiber with removable receptacle for perfect cleaning access
 - User replaceable ribbon patch cord cartridge for quick and low cost MPO (MT) ferrule replacement
 - Wide wavelength range from 1280 nm to 1650 nm
 - Rugged module housing for outside plant operation

Specifications: N3940AA 1x12 Optical Switch

All typical values at 1310nm, 1550nm, 1625nm

Configuration	1x12	
Wavelength range	1280-1650 nm	
Insertion loss ^a	2.7 dB	
Polarization depended loss	±0.05 dB	
Return Loss	Straight Physical Contact	40 dB
	Angled Physical Contact	50 dB (max)
	Repeatability ^b	0.02 dB
	Crosstalk	50 dB

General **Operating temperature:** 0 °C to 50 °C
Storage temperature: -40 °C to +60 °C
Dimensions: 217 mm H, 212 mm W, 33 mm D
Weight: 1.4 kg (3.1lbs)
Maximum Optical Input power: 200 mW (+23 dBm max)
Power Consumption: 1 W
Port to port switching speed: 100 ms

[a] The insertion loss is specified without input and output connectors. The input connector adds typically 0.2 dB. The MPO output connector adds typically 0.5 dB

[b] With instrument in a static position at a constant temperature of 25 °C

Chromatic Dispersion (CD) Analyzer Test Engine

Agilent N3916AL

Description *A quick and easy one-button fiber type identification and chromatic dispersion measurement.* The intelligent chromatic dispersion test algorithms and the factory pre-set measurement parameters give the user information on fiber type and accurate chromatic dispersion at a single press of a button. Access to only one fiber end is necessary. With the combined measurement capabilities of a 4-wavelength OTDR and a chromatic dispersion measurement, the fiber loss and chromatic dispersion tests can be done in one go.

For easy ordering of the correct dispersion compensation module, the chromatic dispersion test specifies the values for dispersion and the dispersion/dispersion slope ratios as a function of wavelength.



CD Test

Features and Benefits

- Full range CD from 1250 nm to 1700 nm
- Full automation (single button)
- Single-ended
- Fiber-mix detectable
- 4- λ OTDR capabilities

Specifications: Chromatic Dispersion Analyzer Test Engine

Typical values are printed in **BOLD**.

For further specifications, please consult "Specifications: OTDR Test Engines" on page 8

The chromatic dispersion analysis requires an end reflection of at least 4% (-14dB). This is provided by a straight connector or an open fiber. If you are using the Chromatic Dispersion Analyzer Test Engine with a fiber terminated with an angled connector, we recommend a mirror, such as the Agilent 81000BR, or an angled to straight patchcord to ensure sufficient reflection.

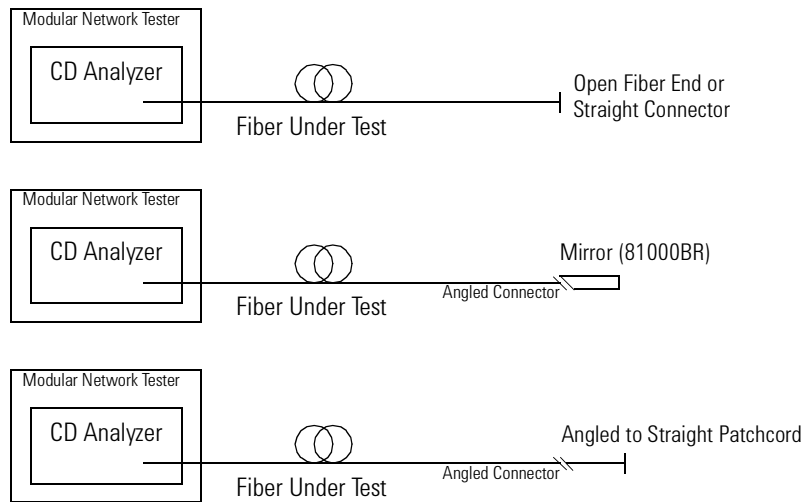

Chromatic Dispersion

Dispersion range		± 2500 ps/nm
Wavelength range		1250 nm to 1700 nm
Zero dispersion wavelength ^a	Repeatability	± 0.6 nm
Dispersion coefficient ^b	Accuracy	± 0.5 ps/nm/km
	Repeatability	± 0.05 ps/nm/km
Dynamic range		38 dB^c
Wavelength resolution		Min. 0.1 nm

[a] 25 km dispersion shifted fiber, 2nd order fit

[b] 25 km non-zero dispersion shifted fiber, 4 term Sellmeier fit

[c] with 96% end-reflection (Agilent 81000BR mirror); 32dB with 4% (-14dB) Fresnel end reflection (open fiber or straight connector)

Polarization Mode Dispersion (PMD) Analyzer Test Engineⁱ

Agilent N3909A

Description The Agilent Technologies Polarization Mode Dispersion Analyzer is the first and only field portable PMD analyzer based on the “golden standard” Jones Matrix Eigenanalysis method. Agilent Technologies has made this method fast and reliable for field use and has significantly reduced the impact of fiber movement and vibration on measurement results.



PMD Test

Features and Benefits

DGD-based PMD results for relevant results

The true cause of trouble in fibers or networks is the differential group delay (DGD). PMD, which is the mean value of the DGD, therefore serves as an indicator of possible problems.

Agilent's N3909A Polarization Mode Dispersion Analyzer measures the DGD directly, and calculates PMD as the average. This approach not only gives you access to the DGD value for particular wavelengths of interest, but also ensures results that are uniquely repeatable and reliable for a field tester. The DGD value enables precise troubleshooting, and the repeatability and reliability of the results increase the confidence of your decisions – for example, on regenerator spacing or the bandwidth potential of fibers. The bottom line is significant cost reductions as you optimize your network design.

- Features**
- Measures DGD vs. wavelength
 - Measures 2nd order PMD vs. wavelength
 - Can troubleshoot a link for DGD/PMD
 - Measures loss vs. wavelength
 - Full automation (single button)

Specifications: N3909A Polarization Mode Dispersion Analyzer Test Engineⁱⁱ

Wavelength Related Parameters	Wavelength range	1525 nm to 1620 nm
	Wavelength readout resolution	50 pm

^{i.} The information for the Polarization Mode Dispersion Analyzer Test Engine had not been finalized at the time of going to print. Please contact your Agilent representative for current details.

DGD Related Parameters	DGD uncertainty ^{a, b}	$\pm(100 \text{ fs} + 3\% \text{ of DGD})$
	DGD range	0 to 150 ps
PMD Related Parameters	PMD range	0 ps to 50 ps
	PMD uncertainty ^{c, d, e}	$\pm(0.03 \text{ ps} + 2\% \text{ of PMD})$

General Characteristics

Link loss uncertainty ^f	$\pm 0.8 \text{ dB}$
Relative link loss uncertainty ^f	$\pm 0.4 \text{ dB}$
Measurement time	< 45 s
Maximum link loss ^{g, h}	50 dB

Optical Interfaces

Output connector: optional FC/PC, DIN 47256, ST, FC/APC, SC, E2000, LC, MU. All are user-exchangeable.

General

N3909AR PMD Receiver Module

Dimensions: 217 mm H, 212 mm W, 33 mm D.
(8.6" x 8.4" x 1.3")

Weight: net <1.2 kg (2.5 lbs)

Operating temperature: 0°C to +40°C

Storage temperature: -40°C to +60°C

Humidity: 95% R.H from 0°C to +40°C.

N3909AS PMD Light Source Unit

Dimensions: 88 mm H, 213 mm W, 380 mm D.
(3.5" x 8.4" x 15")

Weight: net <5.2 kg (11.5 lbs)

Operating temperature: 10°C to +35°C

Storage temperature: -40°C to +70°C

Humidity: 80% R.H from 10°C to +35°C.

Agilent N3909AS PMD Light Source Unit

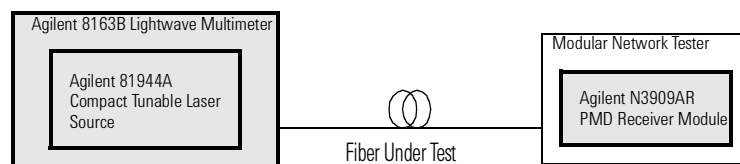

The Agilent N3909A PMD Test Solution consists of the Agilent N3909AS PMD Light Source Unit and the Agilent N3909AR PMD Receiver Module

[a] For DGD < 50 ps.

Value is typical for DGD > 50 ps.

[b] Verified using a calibration device traceable to national standards.

[c] For PMD ≤ 20 ps.

Value is typical for PMD > 20 ps.

[d] 100nm wavelength span.

[e] Derived from DGD uncertainty.

[f] Connector uncertainty not included

[g] For $1570 \leq \lambda \leq 1620 \text{ nm}$:

47 dB over whole wavelength range.

[h] With loss variation of $\leq 10 \text{ dB}_{pp}$ over the measured wavelength range

ii. Specifications for the Agilent 81944A Compact Tunable Laser Source and the Agilent 8163B Lightwave Multimeter Mainframe that make up the Light Source Unit for the Agilent N3909A Polarization Mode Dispersion Analyzer Test Engine are available in their respective data sheets. Please contact your Agilent representative for details.

Optical Spectrum Analyzer (OSA) Test Engine

Agilent N3935A

Description The Agilent DWDM (dense wavelength division multiplexing) Optical Spectrum Analyzer N3935A is designed to be attached in a second onto the Modular Network Tester N3900A. Each DWDM Optical Spectrum Analyzer has built-in RISC processing power for fast and accurate trace acquisition and data processing. With the dynamic software architecture, the DWDM analysis application is uploaded in seconds and enables plug and play operation. DWDM Optical Spectrum Analyzer test engines can be exchanged and shared between multiple users without mainframe software changes, providing efficient and reliable installation and maintenance service.



OSA Test

Features and Benefits

Broad wavelength range with excellent measurement accuracy

The DWDM Optical Spectrum Analyzer is capable of characterizing DWDM systems in the S-, C-, and L-bands and beyond. This includes optical spectrum characterization both before and after optical amplifiers. With a scanning resolution of 0.005nm, a relative wavelength accuracy of 0.02 nm and excellent spectral dynamic range Agilent's DWDM Optical Spectrum Analyzer is designed to be used in systems with down to 25 GHz channel spacing.

Optical signal quality characterization

The quality of an optical DWDM spectrum is characterized by the measurements of power, wavelength and optical signal to noise ratio (OSNR). Agilent's DWDM Optical Spectrum Analyzer offers a spectral dynamic range of 45 dBc @ 100 GHz and 40 dBc @ 50 GHz. This leaves enough margin to detect signal deterioration and locate faults.

Small, lightweight and rugged

Within a form factor of 217 mm H x 212 mm W x 90 mm D (8.6" x 8.4" x 3.5") and with a weight of than 2.5 kg Agilent's DWDM Optical Spectrum Analyzer offers performance which enables full characterization of optical DWDM signals. The Modular Network Tester mainframe and all its modules have been designed to survive harsh outside plant conditions.

On to the next task

The N3935A DWDM Optical Spectrum Analyzer allows testing and qualifying of state-of-the-art DWDM links with the highest efficiency. A real-time mode with its continuous sweep allows quick fault isolation as well as commissioning of DWDM systems. Averaging of several measurements reduces the noise level significantly. One-button testing allows the completion of predefined jobs without the need for time-consuming setup. The DWDM Optical Spectrum Analyzer significantly reduces test time.

Features and applications

- Graphical display and results table
- Automated signal find and wavelength location
- Automated channel fault detection and documentation
- Automated OSNR measurement
- Single button, fast data acquisition
- Real-time (continuous) and average measurements
- User defined soft keys
- Pass/Fail test analysis with user defined limits
- Online help
- Display up to 12 DWDM spectrums for comparison
- Minimum data point spacing 0.005 nm
- Multi user profile setting

Specifications: N3935A Optical Spectrum Analyzer

Typical values are printed in **BOLD**.

General Characteristics

Wavelength Range	1450 nm to 1650 nm
Maximum Number of Simultaneous Channels	256
Maximum Number of Sampling Points	40000

Optical Performance^a

Wavelength Related Parameters

Resolution Bandwidth (FWHM)	≤ 100 pm
Absolute Uncertainty	±0.03 nm^b
Relative Uncertainty ^c	± 0.02 nm
Scanning Resolution	0.005 nm

Power Related Parameters

Absolute Uncertainty ^d	± 0.3 dB^e
Relative Uncertainty (versus λ) ^c	± 0.2 dB
Linearity (versus power) ^c	± 0.1 dB
Power uncertainty due to polarization ^f	± 0.05 dB
Readout Resolution	0.01 dB
Optical Rejection Ratio ^g	45 dBc @ 100 GHz 40 dBc @ 50 GHz ≥ 35 dBc @ 25 GHz
Power Noise Level (RMS)	-70 dBm
Maximum Safe Input Power ^h	+30 dBm
Return Loss ^f	> 40 dB

Optical interfaces

Output connector: optional FC/PC, DIN 47256, ST, FC/APC, SC, E2000, LC, MU. All are user-exchangeable.

General

Operating temperature: 0 °C to +40 °C
Storage temperature: -20 °C to + 70 °C
Humidity: 95% R.H from 0 °C to + 40 °C.
Dimensions: 217 mm H, 212 mm W, 90 mm D. (8.6" x 8.4" x 3.5")
Weight: net 2.5 kg (5.5 lbs)
Recommended recalibration period: 1 year

-
- [a] Wavelength range: 1500 nm to 1620 nm
Optical performance characteristics are given after 30 minute warm up time (allow 60 minute acclimatization if storage was at different temperature). Unless otherwise specified, specifications apply to a single channel measurement.
- [b] ± 0.04 nm at ref condition (Signal level -20 dBm; 23 ± 3 °C). The measurement accuracy is traceable to the National Institute of Standards and the Physikalisch Technische Bundesanstalt.
- [c] Signal level: -30 dBm to +5 dBm
- [d] Includes power uncertainty due to polarization
- [e] ± 0.6 dB at ref condition (Signal level -20 dBm; 23 ± 3 °C). The measurement accuracy is traceable to the National Institute of Standards and the Physikalisch Technische Bundesanstalt.
- [f] @ 1550 nm
- [g] ≥ 40 dBc @ 100 GHz and ≥ 35 dBc @ 50 GHz for signal levels above 0 dBm
- [h] Max +15 dBm per channel (0.1 nm)

USB Video Microscope Camera

Agilent N3988A

Description The Universal Serial Bus (USB) Video Microscope Camera N3988A is used together with the Agilent N3900A Modular Network Tester or a standard PC, for the inspection of fiber optic connectors such as those on patch cords or patch panels. The video microscope is connected via a single USB port, and comes complete with a set of exchangeable connector tips to fit all the common connector interfaces. It makes the examination of connectors for debris, scratches and defects extremely easy by displaying the magnified image on the brilliant 10.4" screen of the Modular Network Tester or PC, away from any laser hazards to the eye.



Video microscope connector inspection

Features and Benefits

The video microscope has an optical zoom function with 200 - 400 times magnification. Using the supplied adapter tips you can use it to examine a wide range of optical connectors. One-handed operation allows you to freeze the microscope image with just the press of a button. It can then be saved in JPEG format, and recalled later for documentation and analysis purposes.

- Handheld video microscope with integrated USB interface
- Only one cable needed to connect video microscope camera to Modular Network Tester mainframe
- One hand operation
- Zoom with 200 – 400 magnification
- Image capture key
- Power management for reduced power consumption
- Image documentation
- Optical input power damage level $\geq +30$ dBm
- Free viewer and Image Capture PC software



N3988A Video Microscope with Adapter Tips

Specifications: USB Video Microscope Camera

Storage File Format: JPEG or BMP

Control functions on Video Microscope Camera

- Focus
- Zoom
- Image capture key
- Power-On LED

Interfaces Universal Serial Bus (USB 1.1)
USB Connector Type: Slave

Optical interfaces **Input:** Adapter tips are supplied as standard for FC/PC, SC, FC/APC, SC/APC, patchcord with 2.5mm ferrule.
Optional adapter tips are available for LC, MU, patchcord with 1.25mm ferrule.
All are user-exchangeable.

Note: Please contact your Agilent representative for information on adapter tips for E2000 connectors.

General **Operating temperature:** 0 °C to +50 °C
Storage temperature: -20 °C to +70 °C
Humidity: 95% Relative Humidity from 0 °C to +40 °C
Environmental Protection Class: IP54
Dimensions: 200 mm L, 50 mm D. (7.88" x 1.97")
Weight: 0.2 kg (0.44 lbs),
Power consumption: 1.0 W max
USB Cable length: 2 m (6.5 ft)

Standards UL recognized
CE marked
CSA approved

Ordering Information

Modular Network Tester Mainframe

Description	Agilent Product Number	Quantity
Agilent Modular Network Tester Mainframe	N3900A	_____

Accessories supplied

- Power Supply
- Power Supply Cord (see "Power cord options")
- Battery Lilon
- VGA Adapter Cable
- USB cable
- Soft case
- Shoulder Strap
- Modular Network Tester Mainframe User's Guide in English
Localized User's Guides are available as a PDF file on the Support CD, or by arrangement with your Agilent representative.
- Programming Guide

Power cord options

Description	Option Number	Select One
United Kingdom	900	<input type="radio"/>
Australia and New Zealand	901	<input type="radio"/>
Continental Europe	902	<input type="radio"/>
United States (120 V)	903	<input type="radio"/>
Systems Cabinet Use – IEC 320 C13/C14	905	<input type="radio"/>
Switzerland	906	<input type="radio"/>
Denmark	912	<input type="radio"/>
Republic of South Africa and India	917	<input type="radio"/>
Japan	918	<input type="radio"/>
Israel	919	<input type="radio"/>
China	922	<input type="radio"/>
Thailand	927	<input type="radio"/>

Optional accessories

Description	Agilent Product Number	Quantity
Compact® Flash Card 192 MB	N3980A	_____
Battery Lilon	N3985A	_____
Hard Carrying Case for Modular Network Tester, modules and accessories	N3993A	_____
Mini-Keyboard	E6081A	_____

OTDR Test Engines

Description	Agilent Product Number	Quantity
OTDR Test Engine 1310/1550nm 40/39 dB	N3910AM	_____
Straight physical contact connector	option 021	<input type="radio"/>
Angled physical contact connector	option 022	<input type="radio"/>

Description	Agilent Product Number	Quantity
OTDR Test Engine 1310/1550nm 45/43 dB	N3910AL	_____
Straight physical contact connector	option 021	○
Angled physical contact connector	option 022	○
OTDR Test Engine 1550/1625nm 43/39 dB	N3911AL	_____
Straight physical contact connector	option 021	○
Angled physical contact connector	option 022	○
OTDR Test Engine 1310/1550/1625nm 43/41/ 38 dB	N3914AL	_____
Straight physical contact connector	option 021	○
Angled physical contact connector	option 022	○

See also “Chromatic Dispersion (CD) Analyzer/OTDR Test Engine” on page 24

Accessories supplied

- Each OTDR Test Engine ordered with Option 021 is provided with 81000FI (FC/PC) and 81000 KI (SC) connector Interface
- Each OTDR Test Engine ordered with Option 022 is provided with 81000NI (FC/APC) and 81000 KI (SC) connector Interface
- OTDR User’s Guide in English
Localized User’s Guides are available as a PDF file on the Support CD, or by arrangement with your Agilent representative.
- Support CD

Software

Description	Agilent Product Number	Quantity
Toolkit III – OTDR Remote Control and Trace post processing and acceptance test documentation software package	E6092A	_____

1x12 Optical Switch Module

Description	Agilent Product Number	Quantity
1x12 Optical Switch Module	N3940AA	_____
Straight physical contact connector	option 021	○
Angled physical contact connector	option 022	○

Accessories supplied

- Each 1x12 Optical Switch Module ordered with Option 021 is provided with 81000FI (FC/PC) and 81000 KI (SC) connector Interface
- Each 1x12 Optical Switch Module ordered with Option 022 is provided with 81000NI (FC/APC) and 81000 KI (SC) connector Interface
- 1x12 Optical Switch Module User’s Guide in English
Localized User’s Guides are available as a PDF file on the Support CD, or by arrangement with your Agilent representative.
- Support CD

Optional accessories

Description	Agilent Product Number	Quantity
MPO Ribbon Fiber patch cord with pigtail	N3989AA	_____
MPO ribbon fiber Fan-Out cable to 12 SC/PC connectors with straight physical contact	N3989AB option 021	_____
MPO ribbon fiber Fan-Out cable to 12 FC/PC connectors with straight physical contact	N3989AC option 021	_____
User replaceable Ribbon Fiber Patch cord cartridge	N3991A	_____

Chromatic Dispersion (CD) Analyzer/OTDR Test Engine

Description	Agilent Product Number	Quantity
CD/OTDR Test Engine 1310/1480/1550/1625nm 43/40/41/38 dB	N3916AL	_____
Straight physical contact connector	option 021	○

Accessories supplied

- Each CD/OTDR Test Engine is provided with 81 000FI (FC/PC) and 81 000 KI (SC) connector Interface
- CD/OTDR User's Guide in English
Localized User's Guides are available as a PDF file on the Support CD, or by arrangement with your Agilent representative.
- Support CD

Note: The Agilent N3916AL is only available for straight physical contact connectors.

Optional accessories

Description	Agilent Product Number	Quantity
Reference Reflector	81000BR	_____

Polarization Mode Dispersion (PMD) Analyzer Test Engineⁱ

Description	Agilent Product Number	Quantity
Polarization Mode Dispersion Test Solution Including:		
• N3909AS PMD Light Source Unit		
• N3909AR PMD Receiver Module	N3909A	_____
Straight physical contact connector	option 021	○
Angled physical contact connector	option 022	○
Polarization Mode Dispersion Light Source Unit Including:		
• 8163B Lightwave Multimeter		
• 81944A Compact Tunable Laser Source	N3909AS	_____
Straight physical contact connector	option 021	○
Angled physical contact connector	option 022	○

ⁱ The information for the Polarization Mode Dispersion Analyzer Test Engine had not been finalized at the time of going to print. Please contact your Agilent representative for current details and ordering information.

Description	Agilent Product Number	Quantity
Polarization Mode Dispersion Receiver Module	N3909AR	_____
Straight physical contact connector	option 021	○
Angled physical contact connector	option 022	○
Compact Tunable Laser Source	81944A	_____
Straight physical contact connector	option 021	○
Angled physical contact connector	option 022	○

- Accessories supplied**
- Each Polarization Mode Dispersion Analyzer Test Engine ordered with Option 021 is provided with 81000FI (FC/PC) and 81000 KI (SC) connector Interface
 - Each Polarization Mode Dispersion Analyzer Test Engine ordered with Option 022 is provided with 81000NI (FC/APC) and 81000 KI (SC) connector Interface
 - PMD Analyzer User's Guide in English
Localized User's Guides are available as a PDF file on the Support CD, or by arrangement with your Agilent representative.
 - Support CD

Optical Spectrum Analyzer (OSA) Test Engine

Description	Agilent Product Number	Quantity
Optical Spectrum Analyzer Test Engine	N3935A	_____
Straight physical contact connector	option 021	○
Angled physical contact connector	option 022	○

- Accessories supplied**
- Each Optical Spectrum Analyzer Test Engine ordered with Option 021 is provided with 81000FI (FC/PC) and 81000 KI (SC) connector Interface
 - Each Optical Spectrum Analyzer Test Engine ordered with Option 022 is provided with 81000NI (FC/APC) and 81000 KI (SC) connector Interface
 - OSA User's Guide in English
Localized User's Guides are available as a PDF file on the Support CD, or by arrangement with your Agilent representative.
 - Support CD

USB Video Microscope Camera

Description	Agilent Product Number	Quantity
USB Video Microscope Camera	N3988A	_____

- Accessories supplied**
- Interchangeable connector tips: 2.5 mm universal adapter, FC, SC, FC/APC, SC/APC
 - Soft case
 - USB Video Microscope User's Guide in English
Localized User's Guides are available as a PDF file on the Support CD, or by arrangement with your Agilent representative.
 - Support CD

Optional accessories

Description	Agilent Product Number	Quantity
Adapter tip for patchcord 1.25mm Ferrule	N3988A option 125	_____
Adapter tip for LC	N3988A option 1LC	_____
Adapter tip for MU	N3988A option 1MU	_____

Note: Please contact your Agilent representative for information on adapter tips for E2000 connectors.

System Options and Accessories

Localization The localization options listed below determine the language of the user interface for the mainframe and modules.

The User's Guide supplied with a mainframe or module is in English. Localized User's Guides are available as a PDF file on the Support CD, or by arrangement with your Agilent representative.

At the time of going to print, not all localizations are available for the mainframe or the full range of modules. Please check with your Agilent representative for current availability.

Description	Option Number	Tick to Select
English localization	ABA	<input type="radio"/>
French localization	ABF	<input type="radio"/>
German localization	ABD	<input type="radio"/>
Simplified Chinese localization	AB2	<input type="radio"/>
Spanish localization	ABE	<input type="radio"/>
Portuguese localization	AB9	<input type="radio"/>
Traditional Chinese localization	AB0	<input type="radio"/>
Japanese localization	ABJ	<input type="radio"/>
Italian localization	ABZ	<input type="radio"/>
Korean localization	AB1	<input type="radio"/>
Russian localization	ACB	<input type="radio"/>
Turkish localization	AB8	<input type="radio"/>
Czech localization	AKB	<input type="radio"/>
Polish localization	AKD	<input type="radio"/>

Additional connector interfaces

Description	Agilent Product Number	Quantity
DIN	81000SI	_____
E2000	81000HI	_____
FC/APC	81000NI	_____
FC/PC	81000FI	_____
LC	81000LI	_____
MU	81000MI	_____
SC	81000KI	_____
ST	81000VI	_____

Service and Support Options

Description	Option Number	Select One
Return to Agilent Warranty and Service Plan. Available for 36 months (3 years) or 60 months (5 years).	R1280A	<input type="radio"/>
Return to Agilent Calibration Plan. Available for 36 months (3 years) or 60 months (5 years).	R1282A	<input type="radio"/>

Related literature and further information

Description	Agilent Product Number	Quantity
N3900A Modular Network Tester, Brochure	5988-5065EN	_____

Training Materials

Description	Agilent Product Number	Quantity
Agilent Cleaning Procedures for Lightwave Test and Measurement Equipment (available as a PDF file on the Support CD)	N3900-90AJ1	_____
Agilent OTDR 's Pocket Guide in English Localized versions are available as a PDF file on the Support CD, or by arrangement with your Agilent representative (available as a PDF file on the Support CD)	E6000-91017	_____

Computer Based Training

OTDR Solution User's Course: On the Support CD or available from <http://www.otdr.com>

Safety Information

All laser sources specified by this data sheet are classified as class 1M or class 2 according to IEC 60825-1 (2001).

All laser sources comply with FDA 21 CFR 1040.10 except for deviations pursuant to Laser Notice No. 50, dated 2001-July-26.

The class 1M laser sources (all OTDR test engines) bear the laser label



All modules also bear the CE conformity marking



You *must* return instruments with malfunctioning laser modules to an Agilent Technologies Service Center for repair and calibration, or have the repair and calibration performed on site by Agilent Technologies personnel

Agilent Technologies Test and Measurement

Support, Services, and Assistance

Agilent Technologies aims to maximize the value you receive, while minimizing your risk and problems. We strive to ensure that you get the test and measurement capabilities you paid for and obtain the support you need. Our extensive support resources and services can help you choose the right Agilent products for your applications and apply them successfully. Every instrument and system we sell has a global warranty. Support is available for at least five years beyond the production life of the product. Two concepts underlie Agilent's overall support policy: "Our Promise" and "Your Advantage."

Our Promise

Our Promise means your Agilent test and measurement equipment will meet its advertised performance and functionality. When you are choosing new equipment, we will help you with product information, including realistic performance specifications and practical recommendations from experienced test engineers. When you use Agilent equipment, we can verify that it works properly, help with product operation, and provide basic measurement assistance for the use of specified capabilities, at no extra cost upon request. Many self-help tools are available.

Your Advantage

Your Advantage means that Agilent offers a wide range of additional expert test and measurement services, which you can purchase according to your unique technical and business needs. Solve problems efficiently and gain a competitive edge by contracting with us for calibration, extra-cost upgrades, out-of-warranty repairs, and on-site education and training, as well as design, system integration, project management, and other professional engineering services. Experienced Agilent engineers and technicians worldwide can help you maximize your productivity, optimize the return on investment of your Agilent instruments and systems, and obtain dependable measurement accuracy for the life of those products.

Get assistance for all your test & measurement needs By Internet, phone, or fax.

Online assistance

www.agilent.com/comms/otdr

Phone or Fax

United States:

(tel) 1 800 452 4844

Canada:

(tel) 1 877 894 4414

(fax) (905) 206 4120

Europe:

(tel) (31 20) 547 2323

(fax) (31 20) 547 2390

Japan:

(tel) (81) 426 56 7832

(fax) (81) 426 56 7840

Brazil

(tel) (11) 4197 3600

(fax) (11) 4197 3800

Latin America:

(tel) (305) 269 7500

(fax) (305) 269 7599

Australia:

(tel) 1 800 629 485

(fax) (61 3) 9210 5947

New Zealand:

(tel) 0 800 738 378

(fax) 64 4 495 8950

Asia Pacific:

(tel) (852) 3197 7777

(fax) (852) 2506 9284

Product specifications and descriptions in this document subject to change without notice.

Copyright © 2000-2004 Agilent Technologies

Printed in Germany. April 5, 2004



5988-8190EN



Agilent Technologies