



NetTool™ Inline Network Tester

Network professionals know what a challenge it can be to resolve a troublesome desktop-to-network connectivity problem. Bad RJ crimp? Wrong e-mail server? Duplex mismatch? Or maybe a bad NIC? IP phone not booting up?

There are three typical causes of a network connectivity problem:

- 1. The PC is not properly configured to take advantage of a particular network resource*
- 2. The network resource is not available (or active) on the network*
- 3. There is a cable problem preventing this network connection*

How do you tell what the problem is? Fluke Networks has put an end to the guessing game with the NetTool Inline Network Tester. NetTool combines cable, network, and PC configuration testing in one palm-sized tool, so you'll have everything you need to quickly resolve even the toughest network connectivity problem.



NetTool features

- NEW! VoIP Option – Watch the phone boot, validate QoS configuration, log call control and monitor call quality metrics.
- PC to network connectivity – Connect between two network devices and see common connectivity problems like speed and duplex mismatch, link problems, and errors
- PC's network configuration – Review servers the PC is configured to use, with services offered, name, IP address and subnet
- VLAN and CDP Visibility – See VLAN identification, priority and frame counts for both the PC and network
- Spot available network resources – See the IP address, MAC address, subnet, and services offered by active servers, routers and printers
- Identify protocols on the PC and network – IP, NetWare, NetBIOS, Apple, and other protocols shown to identify mismatches and unwanted protocols
- Distinguish service at a network drop – Determine whether a drop is offering Ethernet, phone, Token Ring, or is inactive.
- Automatically PING key devices – PING as many as 10 pre-selected devices to verify full network availability
- Monitor network health – See frames sent, utilization, broadcasts, errors, collisions for full or half-duplex 10 or 100 Mbps connections - for both the desktop and network conversations
- Problems Log – Alerts you to excessive errors, duplicate IPs, unanswered DNS queries, unwanted protocols and TCP/IP connection failures
- Perform basic cable tests – Check patch cables or installed wiring for length, shorts, split pairs, or opens, including pin-to-pin connection



Vision into the network and PC or IP phone connection

Inline functionality



VLAN and CDP information

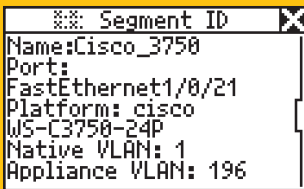

VoIP QoS configuration

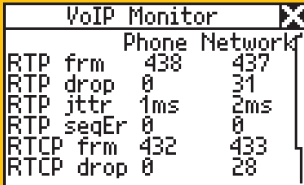

Minimum training time, maximum productivity

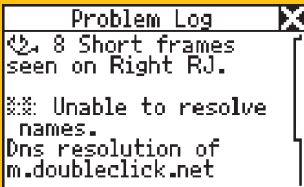

See network resources

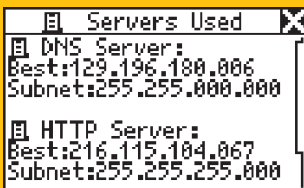
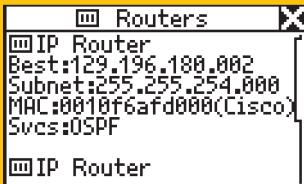

NetTool Pro inline functionality reduces testing time and frustration

Use NetTool Pro to troubleshoot PC and network connections. Connect inline between a PC and the network and see the advertised and actual duplex settings, negotiated speed and link configuration. Then, view the PC-to-network conversation with the PC's network addresses, servers used, VLAN id and CDP information displayed. Also see how the PC is configured: MAC and IP addresses, servers (DHCP, email, HTTP and DNS), routers and printers used.

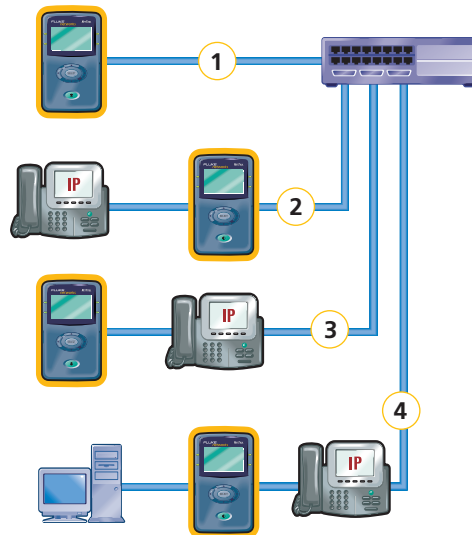

Verify connectivity to other network devices by using the PING feature. PING a default router or another device or select a list of up to 10 network devices. Reporting capabilities show test results – identifying network resources and PC configuration – which can be downloaded and shared with others.

VoIP phone installation

Use NetTool VoIP to verify and troubleshoot IP phone to network connectivity. Technicians can connect NetTool inline between an IP phone and the network and solve many problems without the need of a protocol analyzer. Diagnose phone boot-up problems, call control, RTP stream configuration and measure key call quality metrics such as jitter and dropped packets.

Single end testing

NetTool Standard represents an economical choice for single end testing of network drops or PCs with an easy upgrade path to Pro and VoIP functionality.

Minimum training time, maximum productivity

NetTool is so easy to use, even inexperienced technicians can get up to speed quickly with minimal training. And it's priced so every technician can have one. Reducing the time and expense associated with troubleshooting PC, VoIP and network connection problems, NetTool dramatically increases technician productivity.

VoIP Option testing configurations

Four testing locations shown support the complete VoIP life cycle with testing, monitoring and troubleshooting capabilities at the edge of the VoIP network: before phone installation, with the phone installed and cascaded off the phone.

1. NetTool to switch
2. IP phone to NetTool to switch
3. NetTool to IP phone to switch
4. PC to NetTool to IP phone to switch



Proactively monitor and reactively troubleshoot

WhatsUp Key Device Watch software is an easy-to-use solution included with NetTool that maps the network, monitors key devices, and alerts of failures before they become catastrophes. Key Device Watch software, NetTool and your knowledge give you a powerful combination to help keep your resources up and running.

Key Device Watch monitors 10 key networked resources, waiting for something to go wrong. When something does go wrong, a notification is sent to the proper party letting them know where to go and what to fix. Key Device Watch doesn't solve the problem, but alerts those who can. That information, combined with the handheld network tester, allows the troubleshooter to quickly fix the problem.

WhatsUp Key Device Watch:

- Discovers devices automatically
- Monitors 10 key devices 24x7
- Notifies troubleshooter with problem location and type
- Speeds-up the troubleshooting process
- Provides trend analysis of network diagnostics

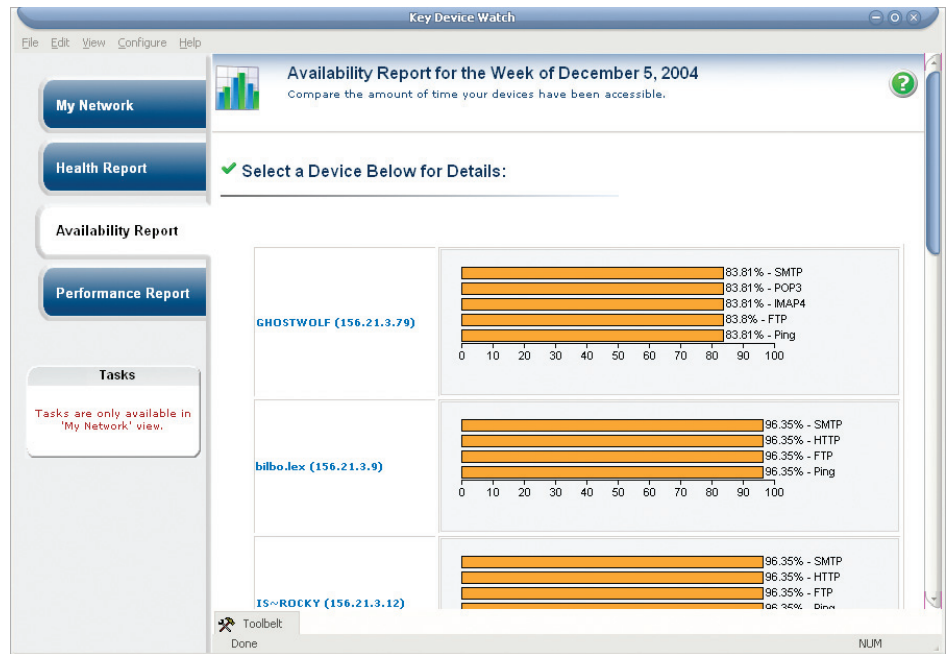

Key Device Watch Availability Report

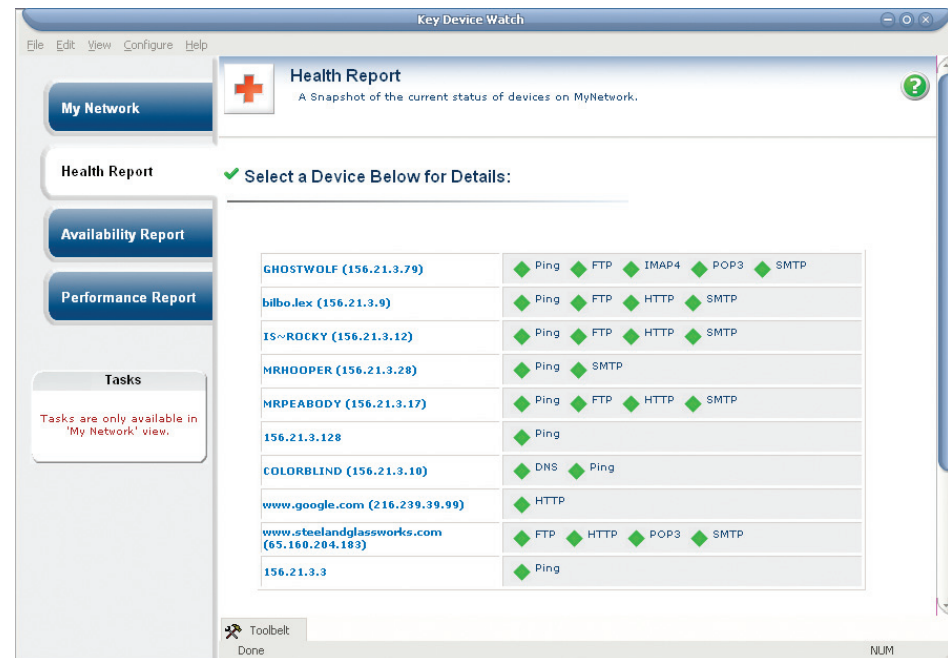

Key Device Watch Health Report



FREE holster with registration

Register your NetTool tester and receive a FREE holster. This durable, soft case protects your NetTool and allows you to hang it up or wear it on your belt. Registration qualifies you for 60 days or three incidents (which ever comes first) of free telephone support. Registered customers may also access our knowledgebase of operation and application articles located on our website.

Network SuperVision Gold Support

Sign up for our Network SuperVision Gold Support plan and you'll enjoy privileges to protect and add value to your equipment. These include unlimited 24x7 technical assistance and an exchange unit at no cost in the event something happens to your unit. Support also includes web based training, unlimited access to the knowledgebase, product discounts and "members only" promotions. See www.flukenetworks.com/goldsupport for details.

For more information about NetTool, visit www.flukenetworks.com/nettool.

Specifications

Media access	10BASE-T and 100BASE-TX
Identifies	10BASE-T, 100BASE-TX (full or half-duplex), Token Ring (4/16 Mbps), Phone* (tip and ring pins), Inactive terminated and open network cables
Call Control	SIP, SCCP (check web site for updates on additional protocols)
Cable Tests	Wiremap, cable length, opens, shorts, and split pairs
Ports	2 Shielded Hub/NIC connector (RJ-45).
Serial port	customized 2.5mm "stereo" input jack
Interface	Push button navigation of icon/menu-driven view
Power	Removable alkaline batteries, optional rechargeable NiMH batteries or optional A/C adapter. Approximately 20 hours continuous use with 4 alkaline batteries.
Dimensions	12.5 cm x 7.8 cm x 4.3 cm (5 in x 3 in x 1.7 in)
Weight	210 g (.46 lbs.)
Warranty	One year (extended warranty available).
LED Indicators	One on each side reporting instantaneous utilization, and one on each side reporting link, collisions and errors

*NetTool can detect telephone signals. However, it is not designed to be used on public telephone networks.

Ordering Information

NetTool models include NetTool tester, serial cable, four AA batteries, wiremap adapter, quick reference guide, WhatsUp Key Device Watch Software mini-CD and CD with users manual and NetTool Blaster update utility software.

Model	Description
NT	NetTool Standard (single-ended testing)
NT-PRO	NetTool Pro (includes inline, reporter and PoE voltage)
NT-VOIP	NetTool VoIP (includes Boot/Call log and VoIP monitor)

Options and Accessories

Model	Description
NT-PRO-OPT	NetTool Pro Option
NT-VOIP-OPT	NetTool VoIP Option
GLD-NT	NetTool Gold Priority Support
NT-AC-ADAPT	NetTool AC Power Adapter
NT-BATT-CHG	NetTool 900 mA Battery Charger
BATT-AA-NIMH AA	Rechargeable Nickel Metal Hydride Battery Pack

NETWORK SUPERVISION

Fluke Networks
P.O. Box 777, Everett, WA USA 98206-0777

Fluke Networks operates in more than 50 countries worldwide. To find your local office contact details, go to www.flukenetworks.com/contact.

©2005 Fluke Corporation. All rights reserved.
Printed in U.S.A. 3/2005 1567676 D-ENG-N Rev G