

IDEAL Cat7 TERA Adapter Set Specs

Provided by www.AAATesters.com



Category 6 and Category 7 Permanent Link and Channel Testing with the IDEAL LANTEK 6/7 LAN Cable Testers

Introduction

IDEAL has taken a fresh approach in designing the Link Adapters for the LANTEK 6/7 LAN Cable testers. When you first open the case of these products, you will immediately notice that traditional Permanent Link and Calibration Adapters are gone. For the LANTEK 6, you will find two Category 6 Test Adapters and two Reference Patchcords with Category 6 plugs at both ends.

In the LANTEK 7 case, there are two Category 7 Tera Test Adapters and two sets of Reference Patchcords. The first set contains Reference Patchcords with Tera plugs at both ends. The second set contains Reference Patchcords with Tera plugs at one end and Category 6 plugs at the other end. (Note: IDEAL is working closely with Nexans to develop a set of Test Adapters utilizing the Nexans GG45 jack. The date for availability of these Test Adapters has not yet been determined.)

The Test Adapters look like traditional Channel Adapters but are more powerful because they are used for Calibration, as well as Permanent Link and Channel testing. How the Adapters and Reference Patchcords are used with the LANTEK 6 is shown in the following Table.

| Type of Test | Cat 6 Channel Adapter | Cat6 to Cat 6 Reference Patchcords | Cat6 to Cat 6 User Patchcords |
|--|-----------------------|------------------------------------|-------------------------------|
| Calibration | X | X | X ₁ |
| Cat6/5e-CLASS E/D Channel | X | | X |
| Cat6/5e-CLASS E/D Permanent Link | X | X | X ₁ |
| 1. Good Quality User Patch cords may be used for Permanent Link Testing if the units have been calibrated with them. | | | |

Figure 1. LANTEK 6 Test Adapter and Reference Patchcord Usage.

Calibration of the Test Units is done with the Channel Adapters and Patchcords. IDEAL supplies Reference Patchcords whose plugs are matched to the jacks in the Channel Adapters. However, the Installer should calibrate with the patchcords that he will use for Permanent Link Testing provided that they are identical, good quality, shielded patchcords. Calibration provides information that is retained by the Test Units about the characteristics of the mated pair used to connect the patchcord cable to the Test Adapter.

Running a Permanent Link test requires the installer to insert one end of a patchcord into the Adapter's jack and the other end into the Permanent Link's jack at both the Near end and at the Far end. Then select the appropriate Permanent Link Test and hit AutoTest. Running a Channel test is exactly the same, except the appropriate Channel test is chosen before hitting AutoTest.

The same benefits apply if you are using a LANTEK 7 and its Adapter and Patchcord configurations are shown in the Following Table.

| Type of Test | Tera Cat 7 Channel Adapter | Tera to Tera Reference Patchcords | Tera to Cat6 RJ-45 Reference Patchcords | Tera to Tera User Patchcords |
|--|----------------------------|-----------------------------------|---|------------------------------|
| Calibration | X | X | | |
| Cat7-CLASS F (Tera) Permanent Link | X | X | | X ₂ |
| Cat7-CLASS F (Tera) Channel | X | | | X |
| Cat6/5e-CLASS E/D Permanent Link | X | | X | |
| Cat6/5e-CLASS E/D Channel ₂ | | | | 3 |
| 2. Good Quality User Patch cords may be used for Permanent Link Testing if the Test Units have been calibrated with them. | | | | |
| 3. Category 6 Test Adapters are required for Channel Testing. They also provide an additional option for Category 6 Permanent Link testing on the LANTEK 7 | | | | |

Figure 2. LANTEK 7 Test Adapter and Reference Patchcord Usage.

The Table shows several additional benefits of this new Adapter design. If the testing plug shows wear, just replace the patchcord, not the Adapter, and recalibrate. And perhaps even more beneficial, good quality 2-meter patchcords with plugs matching the connectors of the installation may be used for Permanent Link testing. Simply calibrate the LANTEK units with the patchcords, select the appropriate Channel or Permanent Link Test and begin testing.

The Design

So, just how can you use the same adapter for both Permanent Link and Channel testing? A very simplistic explanation is that IDEAL has simply replaced the soldered connection that connects the Test Lead to the Adapter with a mated pair connection. A look at the components contributing to an overall Loss measurement are shown in the figure below:

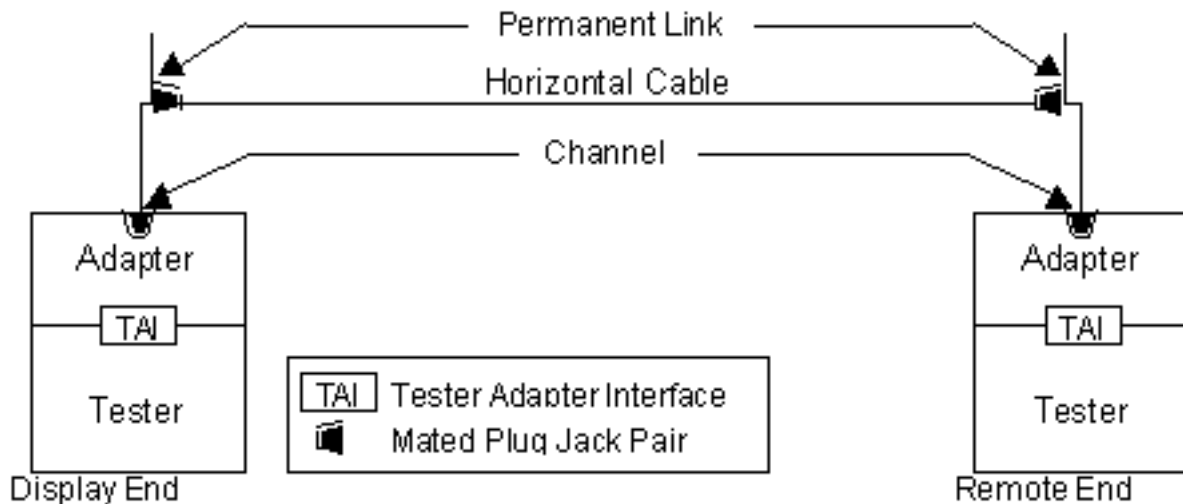

Figure 3. Loss Components of a Total Link

To properly report the Loss Effects of a Permanent Link or Channel, all of the Loss Effects of each of the shown components must be known.

Then, when the overall raw Loss Effects are measured, the background loss effects of the Test Units, Adapters, and the Test Unit/Adapter Interfaces are subtracted to give the Channel Losses.

If the Permanent Link Losses are desired, the Loss effects of the Test Lead patchcords and the mated pair making up the Adapter/patchcord Interface are subtracted from the overall Channel Losses.

The data is collected into a series of fourteen 8 x 8 Matrices for each of the components. A more detailed description of these matrices is provided in Appendix A.

So, each time AutoTest is hit, the tester looks for the test that was selected (Channel or Permanent Link) and executes the appropriate matrix operation to report out the desired results.

RECAPPING THE BENEFITS

Reduction of the Cost of ownership.

By using the same Adapter for Cat 6 Permanent Link testing, Cat 5e Channel Testing and Tester Calibration, LanTek 6 buyers have four less Adapters to buy. And because the same Adapter can be used for Cat 7 Tera Channel testing and Cat 7 Tera Permanent Link Testing, LanTek 7 users also have four less Adapters to buy. And when a Connector vendor requires that the test be run with Adapters using the vendor's proprietary plug, chances are that only a new Reference Patchcord had to be purchased, and not new Adapters.

Reduction in Product Complexity.

With the LanTek 6 and LanTek 7, there are fewer Adapters to manage. That means less confusion when ordering, and less temptation to leave some of the adapters "back at the office, including the one you currently need.

Reduction in Adapter connector wear

The connector between the Adapter and the test unit is a 160-pin connector. IDEAL has reduced the wear on this connector in two ways: First, the Adapter is secured to the tester by a unique connection method developed by IDEAL (patent pending). When the Adapter is inserted and locked, there is absolutely no flexing of the 160-pin connection during day-to-day usage. Further, because the Adapters are multi-use, there are fewer times when the adapter has to be switched, further reducing wear.

Reduction of Maintenance costs.

Installers all know that testing of Permanent Links requires multiple plug insertions as you move from Link to Link. Repeated insertions cause the plug to wear necessitating its replacement. Previously, this meant that the Adapter set had to be replaced. With the LanTek 6 and LanTek 7, only the Reference Patchcord has to be replaced, at considerably less expense.

Reduction Installer test time caused by Adapter switching.

Previously, every time a different test had to run or a Calibration had to be made, the Adapter had to be switched. Many times with the LanTek 7 and LanTek 6, the same Adapter is used and less time is wasted switching adapters.

Have more questions about IDEAL's LanTek 6 and LanTek 7? Log on to IDEAL's Website: www.idealindustries.com and select Products, DataComm, then LAN Cable Testers.

Appendix A

Data is collected by the Tester during Factory calibration, Field calibration and during Autotest (or other test as selected and run under Analyze mode). The collected data is stored in 14 Matrices that are used in producing the selected Test Results.

| | |
|-----------------------|---|
| MNET, MFET | Component Data Matrices for the Near end and Far end Tester Units. |
| MNETAI, MFETAI | Component Data Matrices for the Near end and Far end Tester/Adapter Interfaces. These are the 160-pin connectors that electronically attach the Adapters to the Tester units. |
| MNEA, MFEA | Component Data Matrices for the Near end and Far end Adapters. |
| MNEAPI, MFEAPI | Component Data Matrices for the Near end and Far end Adapter/Patchcord Interfaces. This data is for the mated pairs connecting the Adapters and Patchcords |
| MNEP, MFEP | Component Data Matrices for the Near end and Far end Patchcord cables |
| MNEPPL, MFEPPL | Component Data Matrices for the Near end and Far end Patchcord/Permanent Link Interfaces. This provides the loss characteristics of the mated pair at each end of the Horizontal Cable. |
| MPL | Component Data Matrix for the Permanent Link which includes the Horizontal Cable and the mated pairs at both ends. |
| MTOTAL | Data Matrix containing the raw test result data for all components. |

These Matrices are correlated by the Tester using three formulas. The total losses are represented by: $MTOTAL = MNET + MNETAI + MNEA + MNEAPI + MNEP + MFEP + MFEAPI + MFEA + MFETAI + MFETP$

The Channel Test Results are represented by: $MCH = MTOTAL - (MNET + MNETAI + MNEA + MFEA + MFETAI + MFETP)$

And the Permanent Link Test Results are represented by: $MPL = MTOTAL - (MNET + MNETAI + MNEA + MNEAPI + MNEP + MFEP + MFEAPI + MFEA + MFETPI + MFETP)$

Where:

Data for the Test Units (**MNET, MFET**), Test Unit/Adapter Interface (**MNETAI, MFETAI**) and the Adapters' Return Loss (**MNEA, MFEA**) are gathered and recorded during the Units' Factory Calibration.

Data for the Adapter's NEXT (**MNEA, MFEA**), the mated pair constituting the Adapter/ Patchcord Interface (**MNEAPI, MFEAPI**) and the Patchcord Cable (**MNEP, MFEP**) are gathered and recorded during Field Calibration. (Field Calibration also makes sure the clocks of the Near end and Far end are synchronized).

Finally, the complete data for the Link (**MTOTAL**) is gathered at the time AutoTest time (or at the time an individual test is run under ANALYZE mode). The complete set of matrices allows the Test Unit to set the "Reference Plane" which differentiates the Channel and Permanent Link tests.

The Reference Plane for the Channel is set by removing the effects of the Test Units, the Test Unit / Adapter Interface, and the Adapter. The Channel Test Results are represented by:

$$MCH = MTOTAL - (MNET + MNETAI + MNEA + MFEA + MFETAI + MFETP)$$

The Reference Plane for the Permanent Link is set by removing the effects of the Test Units, the Test Unit / Adapter Interface, and the Adapter. This is represented by the Matrix operation:

$$MPL = MTOTAL - (MNET + MNETAI + MNEA + MNEAPI + MNEP + MFEP + MFEAPI + MFEA + MFETPI + MFETP)$$

IDEAL INDUSTRIES, INC.

Technical Support - Toll Free 877-201-9005

Becker Place, Sycamore, IL 60178 - 800-435-0705 in U.S.A.

Ajax, Ontario, L1S 2E1, Canada - 800-527-9105 in Canada

Warrington, Cheshire WA5 5TN, England - 44 1925 444.446 International

www.idealindustries.com • www.testersandmeters.com