

JDSU HST-3000 T1 Module Specs

Provided by www.AAAtesters.com

HST-3000

T1 Service Interface Module (SIM)



Key Features

- Provides thorough T1 testing including BERT, loopcodes, and NIU/CSU emulation
- VT100 emulation for access to T1, HDSL, HDSL2, HDSL2-4 wire performance statistics
- Copper option adds in-depth copper measurements including DVOM, graphical TDR, RFA/RFL, and load coil counter
- Lower repeat rates with automated close-out tests, scripting, and pass/fail tests loaded with operator-specific thresholds for methods and procedures
- Modular hardware and software architecture allows easy upgrades and enhancements
- Includes T-BERD® advanced stress patterns, intelligent repeater loop codes, and BERT patterns included
- Lightweight, rugged, water resistant, and battery powered handheld test instrument
- NetAnalyst control of Data Network Analyzer test devices
- Supports long-term testing with tabular and graphical results and provides the ability to save configurations and results

The JDSU HST-3000 is the ideal instrument for testing T1 services with built-in functionality that reduces repeat rates, failures, and kickbacks and ensures that all tests are performed the same way, every time.

Reduced budgets, smaller workforces, and untrained technicians can limit a carrier's ability to promptly provision T1 service. Overcoming these obstacles requires resources that facilitate the efficient and rapid deployment of T1 services regardless of whether the T1 line uses traditional repeaters, HDSL with 6 dB noise margin (HDSL2) or HDSL2 four-wire circuits.

Technicians use the HST-3000 optional copper test features to qualify and troubleshoot the circuit, and the T1 test features to bit error rate test (BERT) the line and verify the service. With the VT100 emulation feature, the HST-3000 provides instant access to HDSL/2/4 performance statistics. Technicians do not have to switch instruments or modules, because the HST-3000 combines all the tests into one tool with one common interface. The HST-3000 custom scripting feature automates the testing process, ensuring that tests are conducted completely and thoroughly every time and helps reduce repeat rates and failures by ensuring that the processes used to test are consistent.

With the HST-3000, technicians can complete faster service turn-ups, reduce failure rates, and lower costs, which are all key components to surviving in today's competitive environment.

Summary Settings	
CONFIG->SUMMARY	
1 - Test Mode	Terminate
2 - Pri. Input	Terminate
3 - Payload	Full Rate
4 - Framing	ESF
5 - Line Coding	B8ZS
6 - Pattern	3 in 24

SUMMARY | DS1 | PATTERN | LOOP ▶

Functional Overview

Beginning with the construction of the circuit, and throughout the life cycle of the service, operators must verify that customers are receiving the quality they ordered. Whether qualifying the copper before handing the circuit over to an installation and maintenance crew, technicians must run a BER test. JDSU offers the HST-3000 to prequalify the circuit to ensure that it will run T1 service error free.

BERT Results	
HOME->T1->BERT (TERM, Full T1)	
Primary	
Pattern Sync	ON
Pattern Losses	0
Sync Loss Seconds	0
Bit Errors	0
Bit Error Rate	0.00E+00
Error Seconds	0
Error Free Seconds	344
% Error Free Seconds	100.00
Pattern	3 in 24
Framing	ESF
1 Insert Bit Error	3 Enable Yellow Alarm
Display ▲	Action ▲
Results ▲	Restart

DS1 BERT

To verify proper T1 transmission over a traditional repeatered T1 or an HDSL circuit, technicians must test the entire span from the central office to the customer premises. A true end-to-end service test requires stressing the span and verifying the error tolerance of the copper plant and network equipment. The HST-3000 includes the advanced stress patterns of the T-BERD to properly stress the network.

Primary Event Table				
HOME->T1->BERT (TERM, Full T1)				
No.	Event	Date	Start	Dur./Val.
1	START	02/20/2009	11:40:38.7	1
2	Bit Errors	02/20/2009	11:47:00.5	1
3	Yellow Alarm	02/20/2009	11:47:21.9	On
4	Yellow Alarms	02/20/2009	11:47:21.9	1

Loopback Testing

Preprogrammed HDSL Terminal Unit - Central Office (HTU-C), HDSL Remote User (HTU-R), doubler, T1 Channel Service Unit (CSU), T1 Network Interface Unit (NIU), and repeater loop-codes enable the HST-3000 to quickly sectionalize transmission problems. In addition Pairgain, Teltrend, Adtran, Westell, and ADC equipment-specific loopcodes.

The test set can also emulate T1 customer premises equipment (CPE), simulating a CSU or NIU which allows the test set to be looped up from the central office to verify T1 service across the entire length of the span.

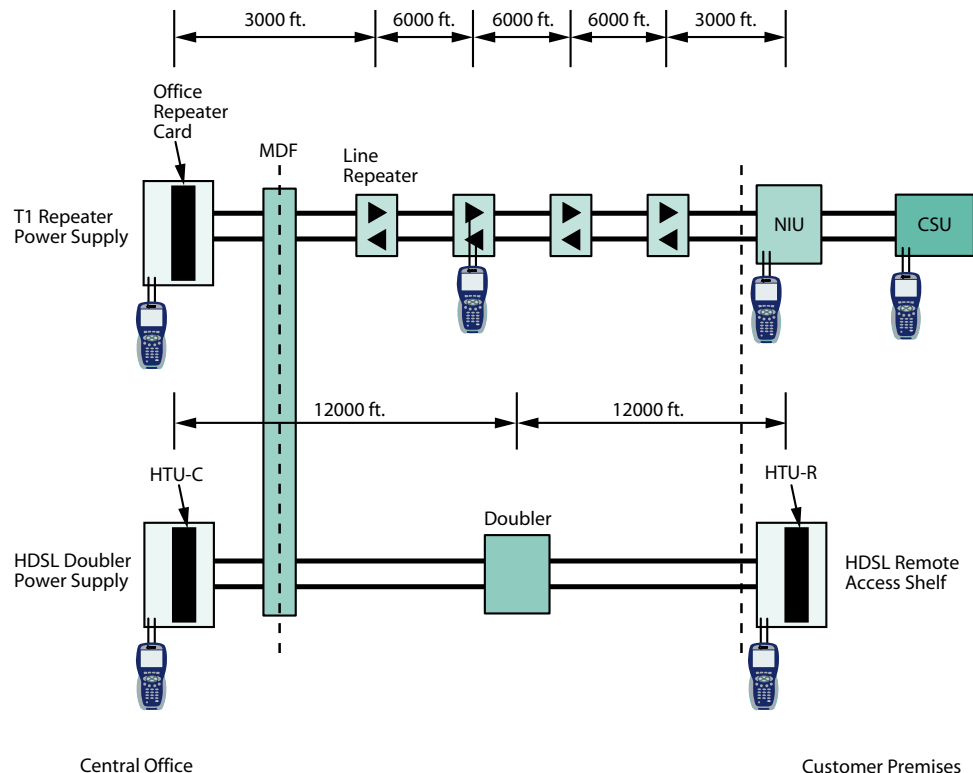

3

Dual T1 Transmit and Receive

The dual T1 transmit and receive capabilities of the HST-3000 provide the ability to measure timing slips, passively monitor T1 circuits in both directions, and perform drop and insert testing. Using the split screen view in dual monitor mode, a span is easily sectionalized to quickly determine the location of a fault. Drop and insert testing allows the user to BERT single DS0s within a T1, without taking the entire T1 out of service.

HDSL/2/4

The VT100 emulation feature lets technicians access HDSL and T1 network equipment for equipment configuration, specific performance data measurements, and loop up capabilities, without having to carry a laptop into the field. With the JDSU repeater extender, technicians can also gain access to the circuit at T1 repeaters.

Fractional T1

The HST-3000 performs fractional T1 (FT1) BER tests on selected channels to verify transmission on contiguous and noncontiguous FT1 bandwidth, which lets the technician verify circuit performance with VF and 577 Hz ID tones at various output levels. In addition, the HST-3000 uses a variety of advanced stress patterns, such as 55 octet, T1-DALY, and other long user patterns as recommended by the ANSI T1.403 standard, to stress repeatered T1/FT1 circuits.

With its enhanced T1 features and functions, the HST-3000 is the ideal test instrument for technicians to troubleshoot and qualify the line swiftly and effortlessly.

Flexible and Rugged Design

The HST-3000 incorporates a rugged, weather-resistant design and long battery life that are ideally suited for use in the field and its modularity allows for field upgrades to support new testing requirements. The HST-3000 is easily upgradeable with technologies and advanced options that support the changing needs of service installers and its dynamic configurability allows it to be used by different technicians with different responsibilities to perform a wide number of tests. Standard Ethernet, USB, and serial connections offer flexibility to easily download software and offload captured test data.

Specifications

Interfaces

Dual Tx/Rx T1	Bantam jacks
Optional dual Tip/Ring and ground	Color-coded, shrouded 2 mm "mini-banana" jacks
10/100 BT Ethernet	8-pin modular
Serial port	BDB9 female via cable (DCE)
USB port	

T1

Payload	Full T1, 56k, 64k, Nx56, Nx64
Input impedance	
Bridge	>100 Ω
Term	100 Ω ±5%
DSX-MON	100 Ω ±5%
Receive level	
Bridge	0 to -20.0 dBdsx
Term	+6 to -35.0 dBdsx
DSX-MON	+6 to -24 dBdsx
Framing	ESF, SF(D4), SLIC-96, unframed
Transmitting timing sources	Internal clock Recovered clock
Line codes	AMI, B8ZS
Line build out level	0, 7.5, 15.0 and 22.5 dB of cable loss at 722 kHz
Line build out tolerance	±1 dB at 722 kHz with LBO or 0 dB
Error insert	Logic, BPV, frame, single, multiple, rate

Physical

Size (H x W x D)	241 x 114 x 70 mm (9.5 x 4.5 x 2.75 in)
Weight (with battery)	1.23 kg (2.7 lb)
Operating temperature	-5.5 to 50°C (22 to 122°F)
Storage temperature	-40 to 65.5°C (-40 to 150°F)
Battery life	10 hrs. typical usage
Charging time	7 hrs from full discharge to full charge
Operating humidity	10% to 80% relative humidity
Storage humidity	10% to 95% relative humidity
Display	3.8" diagonal, 1/4 VGA, Color Active Matrix with backlight (readable in direct sunlight)

General

Ruggedness	Survives 91 cm (3 ft) drop to concrete on all sides
Water-resistant	Splashproof (may be used in heavy rain)
Languages	English, German, French, Spanish, Italian, Chinese, Turkish
Keypad	Typical 12-button keyboard

Ordering Information
Base Unit

HST3000-NG	HST-3000 Mainframe without Copper (Color)
HST3000C-NG	HST-3000 Copper Mainframe (Color)

Available SIMS (Modules)

HST3000-CUCE	Copper only SIM, CE Marked
HST3000-AR2A-T1	ADSL2+ T1 (ATU-R, Annex A)
HST3000-AR2A	ADSL1/2/2+ (ATU-R, Annex A)
HST3000-AR2B	ADSL1/2/2+ (ATU-R, Annex B)
HST3000-AR2B-T1	ADSL2+ T1 (ATU-R, Annex B)
HST3000-CAR2A	ADSL1/2/2+ with Copper (ATU-R, Annex A)
HST3000-CAR2A-T1	Copper, ADSL2+ T1 (ATU-R, Annex A)
HST3000-CAR2B	ADSL1/2/2+ with Copper (ATU-R, Annex B)
HST3000-CAR2B-T1	Copper, ADSL2+ T1 (ATU-R, Annex B)
HST3000-CARB	Annex B Copper/ATU-R
HST3000-CARCA	Copper and ATU-R/C Dual Mode, AoPOTS
HST3000-CARCB	Copper and ATU-R/C Dual Mode, AoSDN
HST3000-CARCE	Copper and ATU-R (Annex A), CE Marked
HST3000-WB2	Wide Band 2 (up to 30 MHz) Copper Test
HST3000-VDSL-CNXT	VDSL with Connexant Chipset
HST3000-VDSL-CNXT-WB2	VDSL and Copper (up to 30 MHz) with Connexant Chipset
HST3000-VDSL-IK	VDSL with Ikanos Chipset
HST3000-VDSL-IK-WB2	VDSL and Copper (up to 30 MHz) with Ikanos Chipset
HST3000-INF-VDSL	VDSL with Infineon Aware Chipset
HST3000-INF-VDSL-WB2	VDSL and Copper (up to 30 MHz) with Infineon Aware Chipset
HST3000-ETH	10/100/1000 Ethernet
HST3000-CT1	T1 and Copper
HST3000-DC	Datacom
HST3000-E1	E1
HST3000-E1-DC	E1/Datacom
HST3000-4WLL	4-Wire Local Loop
HST3000-T1	Dual TX/RX Bantam T1 Interface and T1
HST3000-T3	Dual TX/RX Bantam T1 Interface, and Dual RX/Single TX BNC DS3 Interface/and DS3
HST-BRA	ETSI (Euro) ISDN BRA
HST3000-BRI	ISDN BRI
HST3000-CSHCE	G.SHDSL and Copper
HST-GSH	G.SHDSL
HST3000-GSHCE	2-Wire G.SHDSL
HST3000-CSH4	Copper, 4-Wire G.SHDSL (STU-R/C, Annex A/B)
HST3000-BLK	Blank

Software Options

HST3000-BLUETOOTH	Bluetooth Wireless
HST3000S-WEB	Web Browser
HST3000-REMOP	Remote Operation
HST3000-SCRIPT	Scripted Test
HST3000-DSL2	ADSL2 and ADSL2+
HST3000S-IP	Advanced IP Suite—PING and Through Mode Support
HST3000S-IP-Video	IP Video Analysis
HST3000S-VMOS	Video MOS Analysis
HST3000-MSTV	Microsoft IPTV Video Analysis
HST3000-VT100	VT100 Emulation
HST3000S-VOIP	VoIP Software Analysis
HST3000S-H.323	H.323 VoIP Signaling
HST3000S-MGCP	SCCP MGCP VoIP Signaling
HST3000S-MOS	VoIP Mean Opinion Score
HST3000S-SCCP	SCCP VoIP Signaling
HST3000S-SIP	SIP VoIP Signaling
HST3000-UNISTIM	VoIP Signaling Call Controls for UNISTIM
HST3000-OPTETH	Optical Ethernet
HST3000-IPV6	IPv6
HST3000-MPLS	MPLS
HST3000-MSTR	Multiple Streams
HST3000-TCPUDP	TCP/UDP
HST3000-FTP	FTP
HST3000-WBTONES	WB TIMS
HST3000-PCMTIMS	TIMS (PCM)
HST3000-PCMSIG	Signaling (PCM)
HST3000-SPE	Spectral Noise
HST3000-RFL	RFL
HST3000-TDR	TDR
HST3000-PRI	ISDN PRI (NC Standard)
HST3000-ST	Basic Rate ISDN S/T (ANSI)
HST3000-T1DDS	DDS-T1
HST3000-TxIMP	Transmission Impairments
HST3000-FR	Frame Relay
HST3000-PS	Pulse Shape

Test & Measurement Regional Sales

NORTH AMERICA TEL: 1 855 ASK-JDSU (275-5378) FAX: +1 301 353 9216	LATIN AMERICA TEL: +1 954 688 5660 FAX: +1 954 345 4668	ASIA PACIFIC TEL: +852 2892 0990 FAX: +852 2892 0770	EMEA TEL: +49 7121 86 2222 FAX: +49 7121 86 1222	WEBSITE: www.jdsu.com/test
--	--	---	---	--