

The FTA-02 Fiber Arranger

Guide To Operation



Sumitomo Electric Lightwave Corp.
78 Alexander Drive
Research Triangle Park, NC 27709
Telephone: (919) 541-8100
Toll Free: (800) 358-7378
www.sumitomoelectric.com

All rights reserved. Trademarks mentioned herein are the property of their respective owners.

Document Number:
Revised:

SP-F03-202
April 1999

SUMITOMO RECOMMENDED PROCEDURE

FTA-02 Fiber Arranger

Contents	Page
1. General.....	1
2. Safety Precautions.....	2
3. Reference Documents	2
4. Parts and Ordering Information	3
5. Procedure	4
6. Packing and Shipping	9
7. Troubleshooting and Tips	9
8. Maintenance.....	9

1. General

1.01 This procedure describes the Sumitomo FTA-02 Fiber Arranger.

Note: Before using the arranger in the field for the first time, read this procedure in its entirety and perform a trial run under controlled conditions.

1.02 The FTA-02 fiber arranger is a tool for organizing individual optical fibers into a ribbon for mass splicing. A ribbon can be completed in under 3 minutes, including adhesive drying time.

1.03 The fibers -12 maximum - are stacked in the arranger, clamped, and bonded in a ribbon form with a fast-drying adhesive.

1.04 After removal from the fiber arranger, the ribbon may be stripped, cleaved, and spliced similar to a manufactured ribbon.

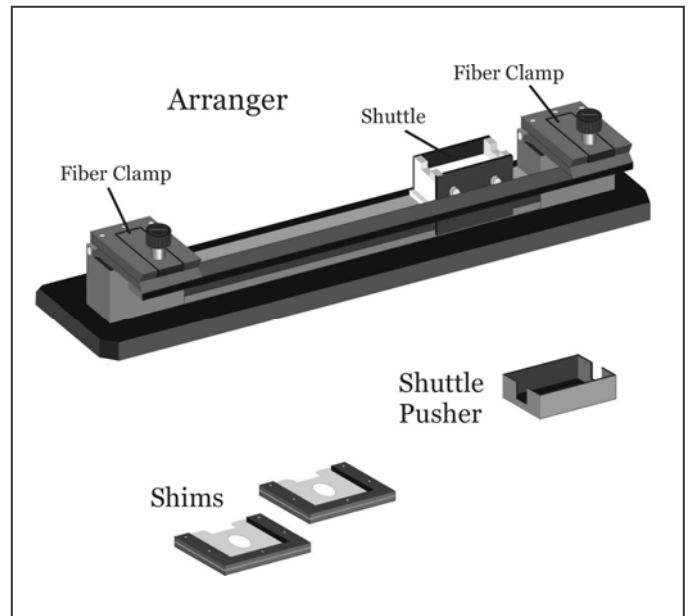

Figure 1. The FTA-02 Fiber Arranger



Ordering Spare Parts

1.07 To purchase spare parts or consumable items, please call our Customer Service at (800) 358-7378 or (919) 541-8100.

Returning for Repair

1.08 To return the unit for repair:

- Call 1-800-358-7378, ask for Fusion Splicer Technical Support at extension 8201.
- If the unit must be returned, obtain a return authorization number (RS#) from the technical support department and write the number on the shipping container.
- Pack the unit (see *Packing and Storage Instructions*) and ship prepaid to:

Sumitomo Electric Fiber Optics Corp.
Technical Services Dept.
78 Alexander Drive
Research Triangle Park, NC 27709
Attn: RS# _____

- For warranty repairs, there is no charge for repair and return shipping.

2. Safety Precautions

2.01 Handle fibers carefully. The fibers can easily puncture skin and break off. Wear safety glasses at all times for protection from glass fibers. Dispose of the fibers properly.

2.02 Handle cleaners such as pure alcohol with extreme caution. Wear safety glasses when using alcohol to clean fibers. If alcohol splashes in the eyes, flush them with cold water and seek medical attention immediately.

Warning: *Do not use alcohol near heat, flames, nor electric arcs, including the arc in the fusion splicer.*

2.03 Read and follow all MSDS (Material Safety Data Sheet) warnings for all products used in this procedure.



3. Reference Documents

Part Number	Description
SP-F03-522	FCP-25 Fiber Cleaver
SP-F03-104A	JR-4A Fiber Jacket Remover
MSDS	Material Safety Data Sheet
SP-F03-516	Type-63 Fusion Splicer
SP-F03-202	FTA-02 Fiber Arrange Tool

4. Parts and Ordering Information

The fiber arranger requires additional materials for forming fibers into a ribbon.

4.01 Equipment

Part Number	Description
FTA-02	Fiber Arranger
N/A	Carrying Case
N/A	Pair - Fiber arranger shims

4.02 Consumables

Part Number	Description
FAC-24	Fiber arranger kit* Contents: 30 Upper Applicators 15 Lower Applicators 1 3M [®] 4475 Adhesive 1 Applicator Removal Tool 1 MSDS
N/A	Cello-Tape
N/A	Gauze Wipes
N/A	Isopropyl Alcohol
N/A	Cotton Swabs

* The FAC-24 kit contains enough supplies for up to 30 12 fiber ribbons.

4.03 For splicing select a fiber holder that matches the fiber type and fiber count. Fiber holders come in left and right matching pairs and are available for the following fiber counts:

- 250, 400, 600 and 900 [m single fibers
- 2 fiber ribbon
- 4 fiber ribbon
- 6 fiber ribbon
- 8 fiber ribbon
- 10 fiber ribbon
- 12 fiber ribbon

4.05 Ordering Information

To purchase spare parts or consumable items, please call our Customer Service at (800) 358-7378 or (919) 541-8100.



5. Procedure

General Information

5.01 This procedure assumes the cable has already been prepared. The following is a summary of the steps required to organize the fibers:

- Prepare the cable (clean and organize)
- Clean all loose fibers
- Arrange the fibers in the tool
- Apply adhesive
- Allow adhesive to dry
- Cut and remove the fiber ribbon

5.02 Before creating a fiber ribbon with the arranger, collect all of the necessary equipment as shown in Figure 2.

5.03 Unpacking the Fiber Arranger

5.03.1 To unpack the fiber arranger, remove it from its carrying case, and place it on a solid, level work surface.

5.03.2 Remove the two shims and shuttle pusher from the arranger and place them next to the arranger.

5.03.3 Locate a pair of applicators. The soft black sponge applicator is the upper one. The harder beige applicator is the lower one.

- Each upper applicator is used to make a single ribbon then discarded.**
- The lower applicator is reversible and is used to make two ribbons before being discarded.**

5.03.4 A wooden pick is included to aid in removing the used applicators.

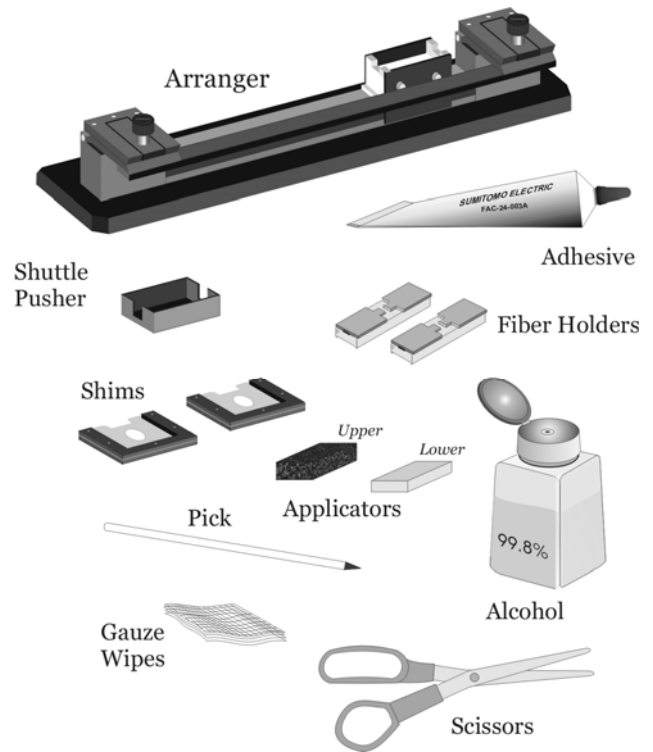

Figure 2. Required Equipment



5.04 Setting Up the Fiber Arranger

5.04.1 To prep the cable prior to using the fiber arranger, strip the jacket according to local practice (in the absence of specifications the total prep length is 36 inches, the ribbon length is 4 inches and the extra length is 3 inches).

5.04.2 The sections that follow assume that the arranger is oriented with one side toward the cable and with free fiber ends protruding from the other side of the arranger. The shuttle is initially located on the cable side as shown in Figure 3.

5.04.3 Use gauze wipes and alcohol to clean the gel from the exposed fibers.

5.04.4 Unfasten and raise the fiber clamps to the vertical position.

5.04.5 As shown in Figure 4, insert the lower (harder) applicator in the shuttle and slide the shuttle to the cable end of the unit and insert the upper applicator in the shuttle pusher.

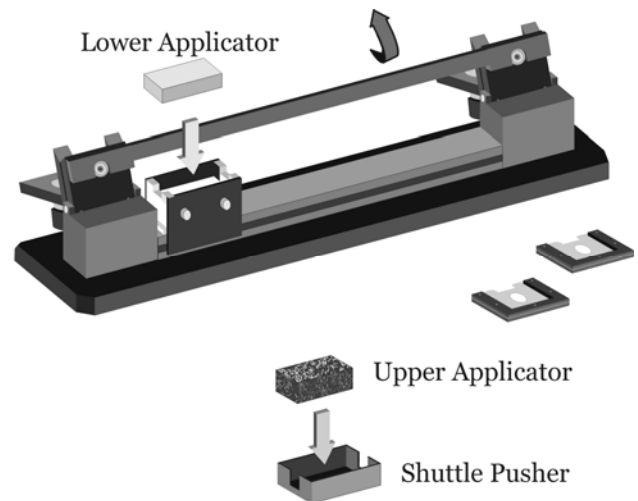

Figure 4. Preparation

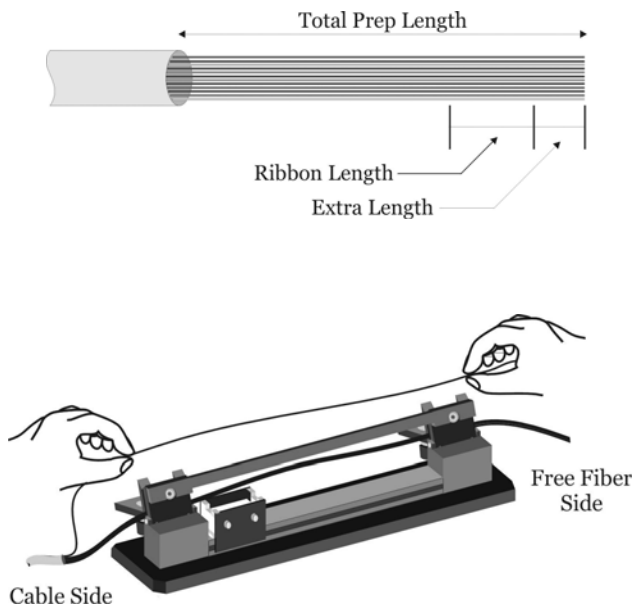

Figure 3. Orientation



5.05 Arranging the Loose Fibers

Note: Refer to Figure 5 when performing these steps.

5.05.1 ✂ Insert each fiber for arrangement one at a time, by sliding the fiber straight down into the vertical slots of the fiber clamps. Order the fibers from bottom to top by standard color code (or other markings on the fibers). The fiber ends must extend at least 3 inches (8 cm) past the end of the fiber guide.

5.05.2 ✂ When all of the fibers are inserted, insert both shims loosely, then lower the fiber guides to the horizontal position.

5.05.3 → While maintaining gentle pressure on the cable side shim, close the fiber clamp and securely tighten.

5.05.4 ↓ Maintaining gentle pressure on the free fiber side shim, grasp the free fibers and pull outwards to remove any slack or air gaps between the loose fiber ribbon section. While still holding the loose fibers and maintaining pressure on the shim, securely fasten the fiber clamp.

5.05.5 Ensure there are no gaps between each fiber or slack on the ribbon section of the arrangement. If gaps are present try the following:

1. Ensure the ribbon section is taught by loosening the free fiber side clamp and pulling the fibers outwards again.
2. Lightly run the edge of the pick (or pencil / pen) across the ribbon section of the arrangement from one side to another.
3. Ensure there are no fiber crossovers by inspecting the fiber order inside both the left and right fiber clamps.

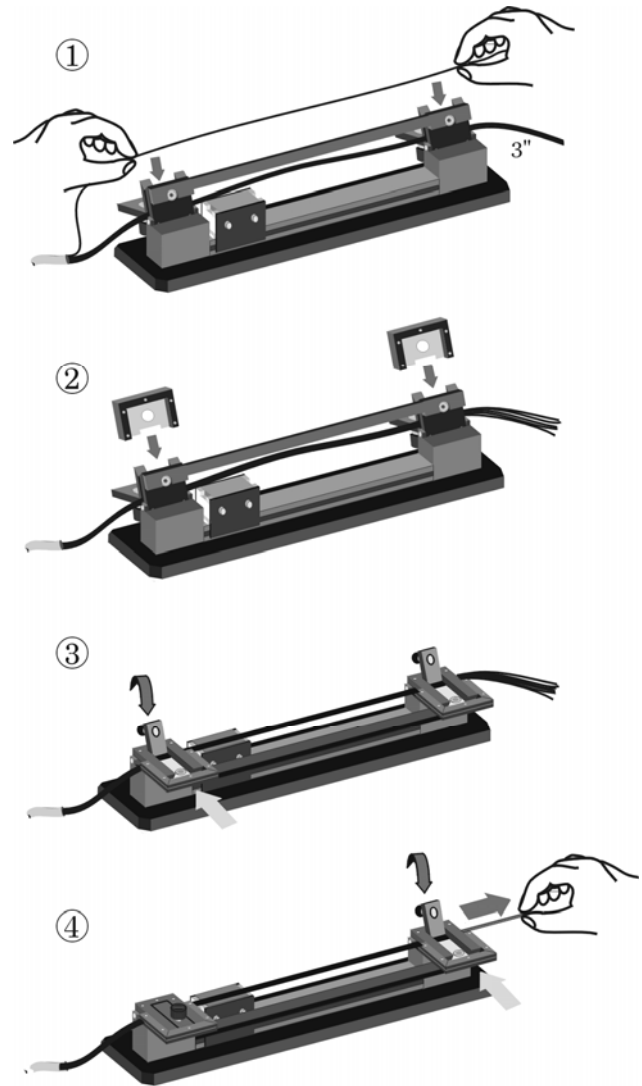

Figure 5. Arranging Fibers



5.06 Applying Adhesive

5.06.1 Then next step must be followed quickly and without interruption because of the fast-drying adhesive used to bond the fibers. If necessary, review the steps prior to beginning.

5.06.2 To apply adhesive to the lower applicator begin by raising the fiber guide upwards. The shuttle should still be positioned at the cable end of the track.

Note: *Beginning with the shuttle at the cable end ensures that the ribbon produced will be free of any small amounts of excess glue on the splicing end of the ribbon.*

5.06.3 Uncap the adhesive and apply a thin bead (1/2 X 3/16 in., 12 X 5 mm) lengthwise along the center of the lower applicator (refer to Figure 6). Once the adhesive is dispensed quickly cap it and set it aside.

5.06.4 ← Return the fiber guide down to a horizontal position.

5.06.5 Place the shuttle pusher with the upper applicator installed, on top of the shuttle such that it caps the fibers.

5.06.6 ↑ Pushing the shuttle pusher down on top of the shuttle, slide the shuttle across the fibers towards the free fiber side.

5.06.7 → Without hesitation return the shuttle back to the cable side.

5.06.8 ↓ Immediately remove the shuttle pusher and raise the fiber guide.

5.06.9 Allow the adhesive to dry for 45 seconds

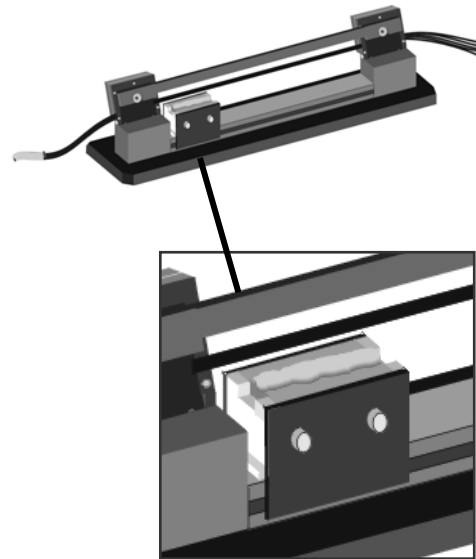

Figure 6. Applying Adhesive

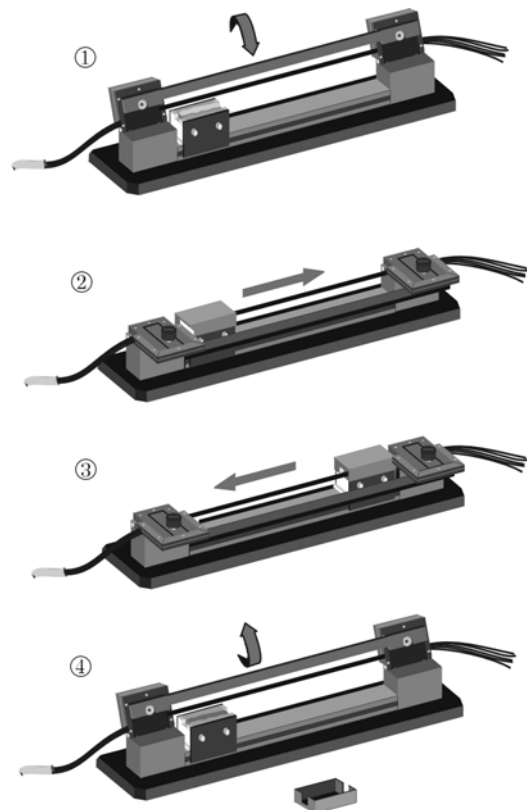

Figure 7. Ribbonizing Process



5.07 Ribbon Completion

5.07.1 When the adhesive has dried completely (45 seconds) remove the lower applicator from the shuttle and lower the fiber guide down to a horizontal position.

5.07.2 Loosen the thumbscrew on the free fiber side end of the arranging tool. Use a pair of scissors to cut the ribbon 1/4 in. (6mm) from the fiber clamp on the free fiber side. Discard the scrap fibers

5.07.3 Loosen the thumbscrew on the cable side of the arranger. Remove the shims from both fiber clamps and set them aside. Remove the finished ribbon from the fiber arranger and set it aside.

5.07.4 Use the wooden pick to remove the lower applicator. Turn the applicator over so that it can be re-used. Remove the upper applicator from the shuttle pusher and discard.

5.07.5 Place the ribbon in a fiber holder for the appropriate fiber count in preparation for stripping cleaving and splicing.

5.07.6 Once the ribbons are constructed, proceed to splice the ribbons as for the factory manufactured product. Refer to *SP-F03-516 Type-63 Sumitomo Fusion Splicer* for details of the splicing operation.

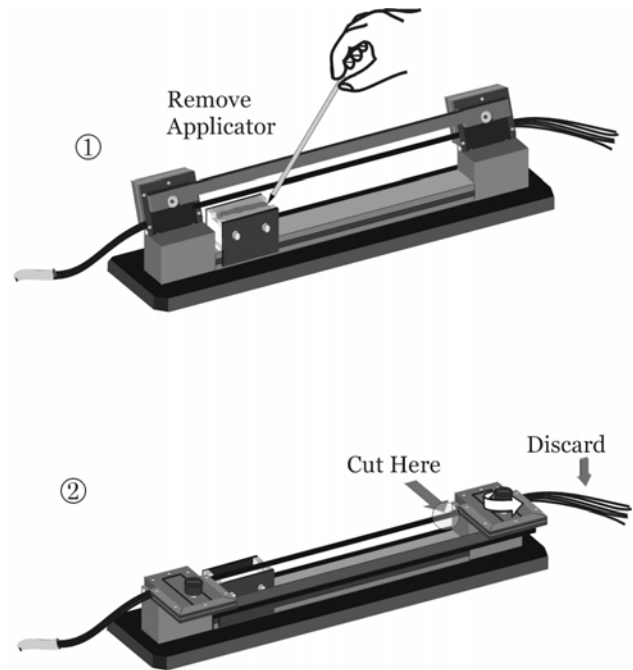

Figure 8. Completing the Ribbon



6. Packing and Shipping

6.01 Remove both the upper and lower applicator from the arranger, and discard them. Remove any scrap fibers and discard them as well. Be sure the adhesive dispenser is capped and securely closed.

6.02 Use cable cleaner and gauze wipes to clean any adhesive accumulation from the tool, shims, and shuttle pusher. After cleaning, insert the shims in the fiber clamps and return the clamps to horizontal and lock.

6.03 Put the arranger and accessories in its case and close the case.

6.04 Here is a packing list:

- Both applicators and fibers removed
- Adhesive capped
- Routing cleaning
- Left and right shims inserted
- Both clamps to horizontal
- Fiber arranger packed

7.0 Troubleshooting and Tips

To reach Sumitomo Technical Support, dial 1-1-800-358-7378.

See the General Section *1.0* for information about returning equipment to the factory.

7.01 If a fiber cannot be inserted into one or both fiber clamps, attempt to clean the slots with one of the shims. Moisten the shim with cable cleaner and gently "saw" it into the slots of the arranger to remove any dry adhesive.

8.0 Maintenance

8.01 After each use, wipe the fiber arranger, shuttle, shuttle pusher and shims with cable cleaner to remove any residual adhesive.

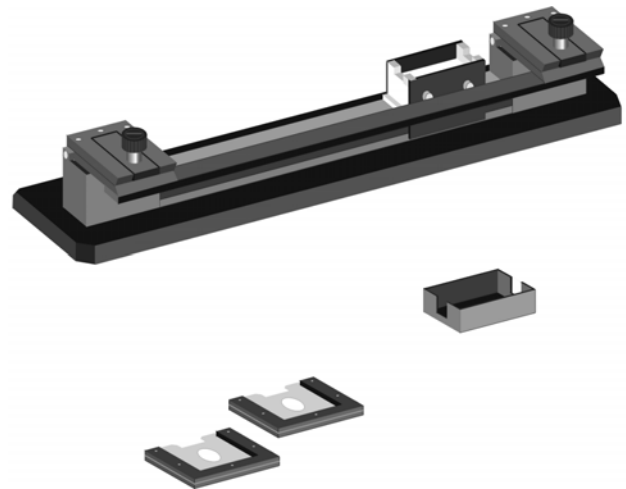

Figure 9. Clean with cable cleaner