



Communications Analyzer

As more and more of your customers demand advanced SONET and ATM services, it becomes critical to have the capability to test multiple technologies *without* requiring multiple test sets. Meet the T-BERD® 310—the total network test tool that packs SONET, ATM, DS3, and DS1/0 testing power into one dynamic instrument. The T-BERD 310 possesses one of the testing industry's best performance and reliability records and is approved by more service providers than any other SONET tester.

Flexible T-BERD 310 packages take the guesswork out of SONET testing by offering electrical, optical, and high-speed optical options tailored to meet your special needs. When you're ready to add ATM testing or DS0 through OC-48 speeds, you can include them with a simple field upgrade without affecting existing features. An optical spectrum analyzer for testing dense wave division multiplexing (DWDM) networks is also included in the T-BERD 310's portfolio of field-upgradeable options. Plus, an internal modem option and a suite of graphical remote software packages enable you to isolate problems remotely before dispatching a technician.

By regularly adding options to your T-BERD 310, you'll maximize your investment and ensure that you stay up-to-date with today's services. As technology changes and your networks grow, you can count on the T-BERD 310 to support you with convenient, easy-to-use upgrades.



The T-BERD 310 packs SONET, ATM, DS3, and DS1/DS0 testing power into one package.

The T-BERD 310's extensive set of measurements, drop and insert functions, and remote control features give you complete testing capabilities in laboratory, manufacturing, central office, or outside plant environments.



Central Office

Maximize maintenance and troubleshooting efficiency with dual DS3 receivers, extensive DS1 analysis, and a wide range of simultaneous error measurements. Quickly set and verify signal level and frequency using signal analysis and pulse shape measurements; verify timing configuration, circuit setup, and easily troubleshoot mid-span meets. The T-BERD 310 also performs critical optical return loss measurements, so you can install and troubleshoot high-speed optical networks.



Laboratory

Simulate ATM traffic conditions and perform detailed testing using advanced error insertion, complete pulse shape analysis, and jitter measurements. Measure automatic protection switch (APS) time, access jitter spectral characteristics, or access the data communications channel from SONET. Perform automatic DS3 and SONET conformance testing. Utilize the TTC Distributed Test Manager™ (DTM) scripting capabilities to automate regression test suites.

Mobile Telephone Switching Office (MTSO)

Detect physical layer problems and test DS0, DS1, and DS3 through OC-12 at the MTSO. Quickly troubleshoot a wide range of problems associated with wireless networks. Field upgrade to SONET as your cellular network requires higher bandwidth. In one step, scan all 28 DS1s within a DS3 or SONET signal for framing format, errors, timing slips, and alarms. In-service testing is also supported, with DS1 drop and insert on a live DS3 signal.



Manufacturing/Production

Fully integrate the unit into your automated test system with the RS-232/IEEE-488 remote control interface and rack mount capability. The TTC DTM software for Windows® can automate acceptance test suites for maximum flexibility in distributed test applications. National Instruments Corporation's LabVIEW® drivers provide a platform-independent, graphical programming language for the T-BERD 310.



By supporting emerging transport technologies such as DWDM, TTC continues to protect your T-BERD 310 investment. The optical spectrum analyzer allows you to qualify, troubleshoot, and maintain your DWDM network by measuring critical optical parameters to verify system integrity. An internal tunable filter can be set to a specified wavelength to precisely evaluate the appropriate channel in the multi-channel DWDM system. In addition, each DWDM channel can be filtered to an output port allowing selective bit error rate testing (BERT). This allows you to sectionalize problems and qualify each channel in a manner similar to the verification process used with SONET, DS3, and DS1 time domain multiplexing (TDM) networks today. The media test card provides optical return loss and power level measurements, which are critical for evaluating the cables and connectors in high-speed DWDM and SONET networks.

- **Optical Spectrum Analyzer**

Verify the critical parameters—signal-to-noise ratio, center wavelength, and peak power—to qualify your DWDM network and sectionalize troubles in the span. Use the SONET options to BERT each channel using the channel selection feature to drop out a channel for this ultimate qualification test.

- **Dual-Wavelength Optical Return Loss and Insertion Loss**

Qualify existing and future network performance by measuring the total energy reflected back to the transmit source. Proactively verify loss budgets to guarantee network performance for your receiver specifications, using a built-in stable source and power meter.

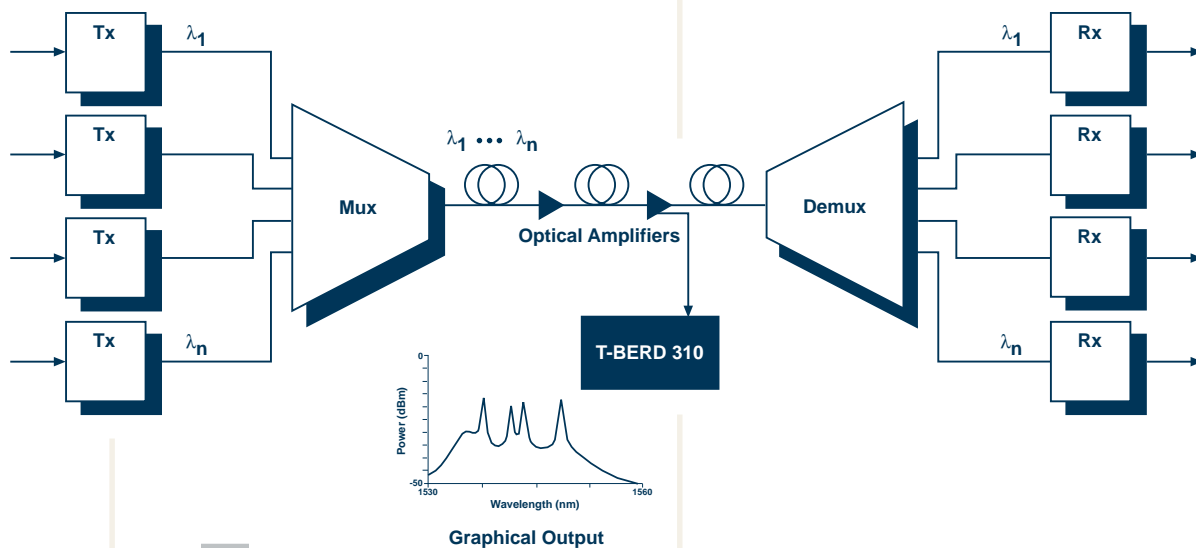

DWDM Testing

Use a printer or laptop computer to tabulate and graph all the channels in the DWDM system. View the graphical output to determine gain tilt and power flatness of the optical amplifiers to ensure equal distribution of power in all channels.

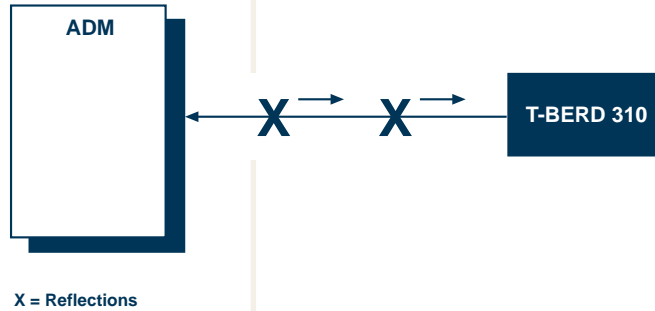

Optical Return Loss Testing

Ensures that the total amount of energy caused by reflections is within specification for the laser type, wavelength, and line rate. A dual-wavelength Optical Continuous Wave Reflectometer (OCWR) source allows you to prequalify fiber to prevent this common problem. It also allows the test set to be used as a stable source for construction or outside plant crews.

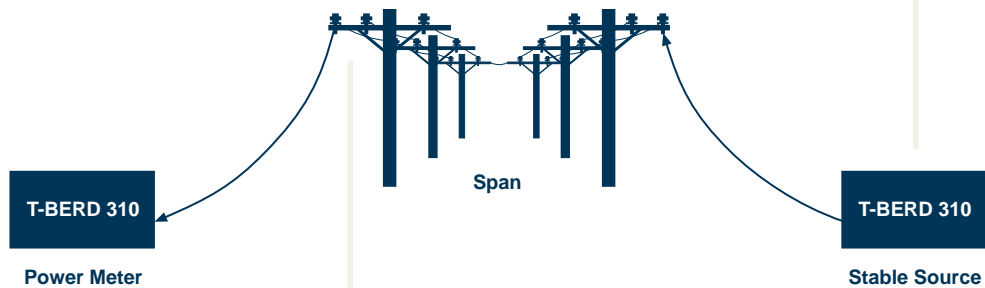

Insertion Loss Testing

Verifies your end-to-end optical power loss is within the design budget. Insufficient insertion loss can cause receiver saturation, while too much insertion loss can cause an unrecoverable signal. Either situation can result in intermittent errors or total system failure.

The flexible architecture of the T-BERD 310 allows you to configure your instrument to meet your specific SONET testing needs. The SONET options are designed around a Reduced Instruction Set Computer (RISC) architecture which provides enhanced flexibility, allowing TTC to quickly respond to changing market requirements with software upgrades. Advanced dual-wavelength laser technology allows complete fiber testing at both 1310 and 1550 nm wavelengths. The T-BERD 310 SONET capabilities include full results analysis, easy-to-read LEDs, and the following features:

- **Automatic SONET, DS3, and DS1 Signal Synchronization**

Immediately identify the SONET payload type and DS3/DS1 framing and pattern with minimal setup. Isolate incorrect equipment configurations.



The T-BERD 310's flexible architecture enables you to configure your test set quickly and easily.

- **Synchronization Messaging**

Easily prevent timing loops and verify clock integrity by evaluating SONET messages.

- **Flashing Messages**

Warn of common problems resulting from improper identification of STS-1 or DS3 signal connections.

- **Simultaneous Results Display**

With a single test, quickly identify which signal is the source of errors while viewing SONET, DS3, DS1, and DS0 results all at once.

- **Concatenated Payloads**

Verify SONET equipment configuration for transporting broadband services. Front panel LED indicates when OC-12c or OC-3c payloads are being received.

- **APS Testing**

Using SONET through mode, simulate real-life signal degradation conditions to verify APS switching.

- **Dual-Wavelength SONET Testing**

Thoroughly test 1310 and 1550 nm wavelengths with a single test set by selecting the desired wavelength for SONET signals. Acceptance testing or problem isolation of 1310 and 1550 nm networks can also be performed with the user-selectable wavelength.

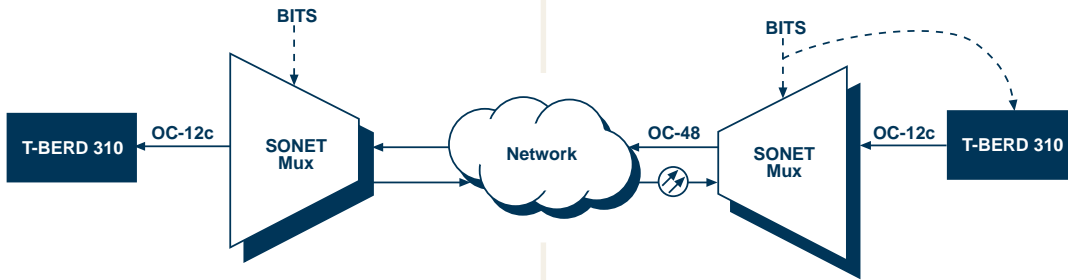

OC-12c Testing

Verifies end-to-end circuit configuration and synchronization setup for service providers or end users. Quickly identifies misconfigured ADM nodes while providing a quick check of the Path Trace and Pointer results to ensure quality transmission of broadband traffic such as ATM.

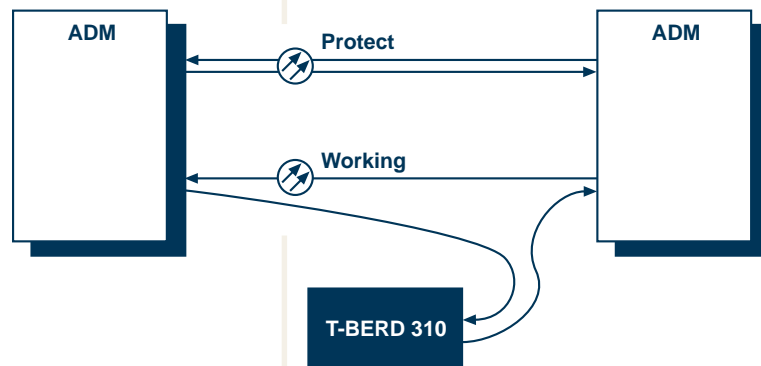

APS Testing

Simulates degraded service to verify APS configuration is correct. Using thru mode, errors can be injected on the actual SONET overhead while using the instrument as a SONET pass-through device and measuring the APS time and side-effects on the DS3 payload.

The T-BERD 310 provides ATM testing capability to allow verification of both public and private networks. Combined with the test set's existing physical layer capabilities, the groundwork can be laid for high quality ATM service. Prequalification of ATM networks is critical in the prevention of congestion and network failures due to higher layer protocols generating excessive cell retransmission.

The unique ATM features of the T-BERD 310 provide comprehensive and easy-to-use ATM layer testing capabilities, including cell search and preview mode, cell loss and delay variation measurements, and OAM cell capabilities. Front panel ATM error and alarm insert, as well as front panel LEDs provide alarm notification and easy access to the ATM signal. In addition, these powerful features are added to field T-BERD 310s without the need to remove any existing options from the test set, protecting your past, present, and future investment.



The TTC ATM test cells go beyond problem isolation, so you can verify QoS and isolate network troubles.

- **ATM Cell Search and Preview**
Quickly locate user-defined ATM cell types and identify active traffic in the network, all with the touch of a button.
- **Traffic Bandwidth Analysis**
Qualify traffic patterns and verify conformance to a specified Quality of Service (QoS).
- **OAM Support**
Transmit AIS, RDI, and loopback cells to troubleshoot switch configuration problems and verify switch response.
- **Cell Transport Verification**
Easily isolate ATM congestion or configuration problems by measuring dropped, misinserted, or out-of-sequence cells.
- **User-Defined Transmit or Receive Cells**
Store multiple ATM headers and assign bandwidths to stress specific ports, or configure the receiver with a mask to filter specific cell types.
- **Delay Variation**
Measure fluctuations in cell interarrival time caused by congestion or statistical multiplexing. Measurements allow you to estimate single-point cell delay variation with minimal setup.

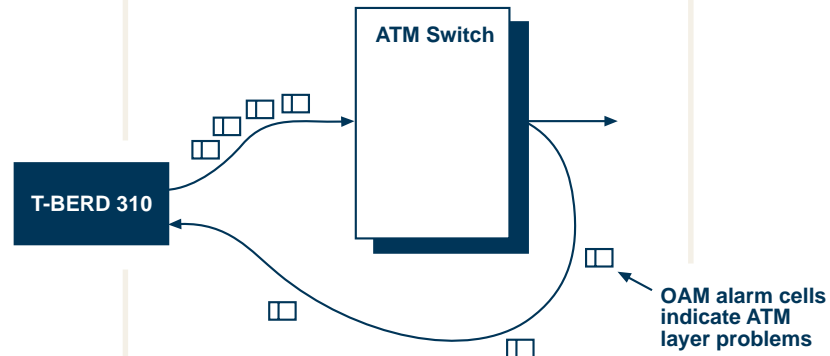
Search Mode

Allows you to quickly identify a user-defined cell type by its address, solving two common switch configuration problems. First, switch configuration tables can be easily misconfigured, resulting in a troubleshooting nightmare of lost customer traffic with billions of address possibilities. With search mode, the entire payload is searched within seconds, and the lost cell address is displayed. Second, ATM AIS and RDI cell-level alarms may be generated or reported by the switch. Finding the exact location of these alarms for correction is simplified with search mode.

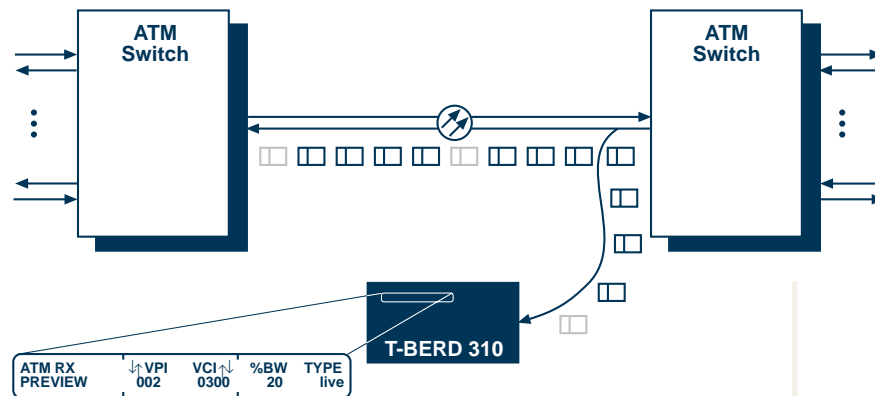
**Preview Mode**

Tells you with the touch of a button which active cells are on the network. When combined with a multicasting switch configuration, preview mode provides a powerful, in-service network monitoring feature. Active cell addresses are displayed, and their bandwidth percentage and cell types are updated in real-time. Cell traffic types include: live (shown), TTC test cells, AIS, or RDI alarms. In addition, any identified cell address can be easily stored for further analysis, including HEC error and congestion percentage measurements.

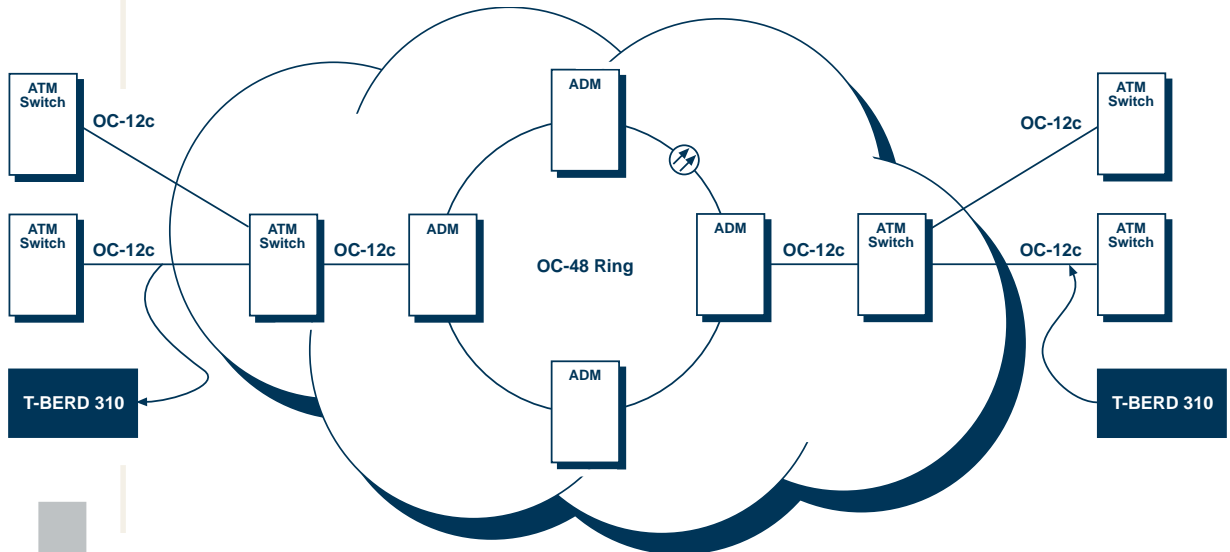

End-to-End Stress Testing

Verifies conformance to QoS standards for constant and variable bit rate services. The T-BERD 310 will emulate the sustained and peak cell rate for a user-definable bandwidth and duration. 100% of the entire bandwidth can be filled with a mixture of idle cells, user-programmable foreground, or background cells. At the far-end, delay variation, dropped cells and network congestion can be monitored for side-effects. For end-to-end connectivity, the user-definable TTC test cell correlation tag provides a unique cell identifier. This testing approach ensures that the full bandwidth range of live traffic will be supported—before the circuit is commissioned.

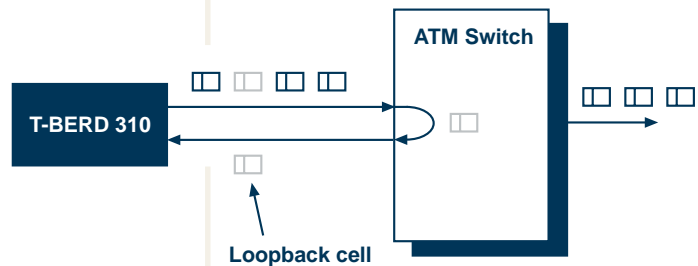

OAM Loopback Testing

Identifies ATM switch configuration problems. Segment and end-to-end loopback cells are sent into the switch or network and automatically routed back via a return channel. Failure to receive loopback cells may indicate improper configuration of bidirectional ATM traffic.

DS3 bandwidth enables you to support a host of new communications technologies, including cellular traffic, video conferencing, distributed data processing, and workstation-based graphics. Like any transmission service, you need to test the physical layer carefully to derive these benefits—especially technologies requiring higher layer error correction, like ATM. To prevent unnecessary cell retransmission, verification of the physical layer is critical. The T-BERD 310 is a full-featured DS3 monitoring and analysis instrument, that enables you to thoroughly verify DS3 circuits in-service and out-of-service. DS3 testing functions include:

- **Pulse Shape and Signal Analysis**

Identify connector and cabling troubles by measuring the DS3 pulse shape's conformance to 1991 and 1993 ANSI and ITU-T specifications. Quickly set signal levels during equipment installation. Correlate error bursts with level dropouts and frequency variations. Print pulse shape graphs and verify adherence to pulse mask specifications.

- **DS3 Jitter Analysis**

Perform in-service DS3 jitter measurements to detect DS3 jitter caused by SONET SPE pointer adjustments, or perform frequency spectrum analysis on the demodulated jitter output signal. Set jitter thresholds to be immediately notified of out-of-specification results.

- **Multiplexed DS3 Signals**

Easily generate and receive multiplexed DS3 patterns while inserting errors on user-selectable DS1 channels. Insert a DS1 pattern into one or all channels to test and simulate 3:1 cross-connects or multiplexers. Test patterns, tones, loop codes, or errors can be inserted on one or all DS1 channels for additional testing flexibility. Front panel LEDs and results monitor the DS2 frame status.



The T-BERD 310's extensive DS3 testing capabilities help you qualify and troubleshoot DS3 circuits.

- **Far-End Alarm and Control (FEAC) Support**

Transmit C-bit FEAC or loop codes to loop specific DS1 channels or measure far-end response. LEDs and the SUMMARY results category notify you when incoming FEAC messages are received.

- **Bidirectional DS3 Testing**

Reduces problem isolation time by half, by utilizing two independent, simultaneous DS3 receivers for full analysis for two live DS3 signals. Front panel LEDs and results let you monitor both directions independently, or automatically generate customized print reports when errors are detected on either receiver.

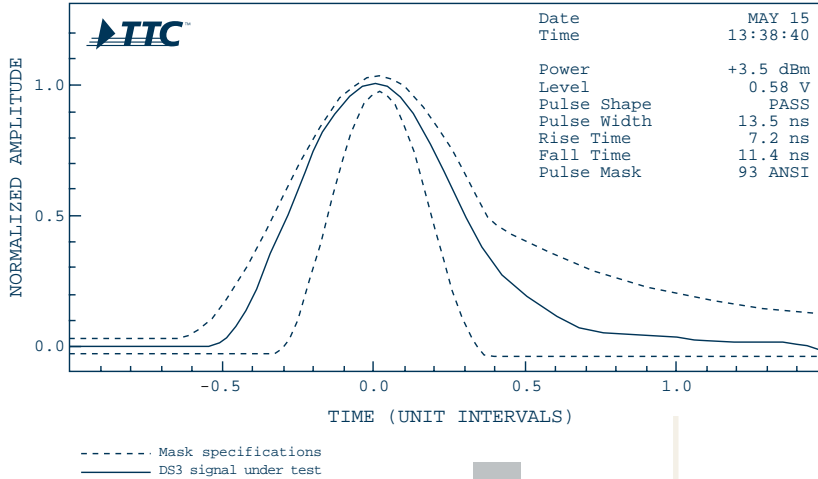

Pulse Shape Testing

Quickly identifies ground shorts, loose or poor connections, or improper cable lengths causing intermittent errors. A printer can be used to output the pulse shape for visual comparison to a user-selectable pulse shape mask. The T-BERD 310 also provides a broad array of signal measurements, including transmit frequency, receive frequency, level, and power to further isolate troubles.

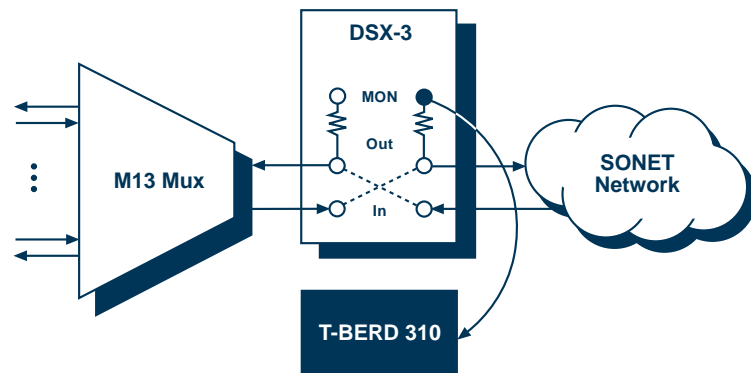

Jitter Testing

Lets you know non-intrusively when synchronization problems exist in the DS3 network or SONET network. Bursty jitter measurements often indicate a timing problem in the SONET network, while stable and a consistently high reading indicates a problem in the DS3 network.

The DS1/DS0 testing capabilities of the T-BERD 310 offer unmatched flexibility for testing at a variety of test access points. At DS1, it acts as a stand-alone DS1 test set. With the flip of a switch, the test set immediately begins analyzing DS1 tributaries at DS3 or SONET access points. These features enable you to install, qualify, and troubleshoot DS1 signals with one test instrument. DS1/DS0 test capabilities include:

- **DS1 Scan and Automatic Payload Detection**

In one step, scan all 28 DS1s within a DS3 or SONET signal for framing format, errors, timing slips, AIS, CRC errors, and alarms. Scan continuously, or trigger and hold on a DS1 with user-selectable error and alarm events. Reduce problem isolation time further by using automatic payload detection.

- **ESF Data Link Analysis**

Decode BITS synchronization messages to verify the quality of network timing sources. Analyze far-end Performance Report Messages (PRMs) per ANSI T1.403. Generate PRMs emulating customer or carrier equipment. Transmit out-of-band line, payload, or network loop codes over the ESF datalink.

- **Programmable Loop Codes and Test Patterns**

Use 3- to 8-bit programmable loop codes for non-standard DS1 equipment, or select standard in-band Facility 1, Facility 2, or CSU, or out-of-band line, network, and payload. Use 3- to 24-bit programmable test patterns for custom tests, or choose fixed, pseudorandom, or long user patterns (LUP).

- **DS1 Timing Slips**

Quickly identify clocking impairments, a common source of intermittent errors in asynchronous networks and jitter in SONET networks. Access your DS1 timing reference from SONET, DS3, DS1, or BITS access points.

- **Line Coding**

Transmit AMI or B8ZS formats. Automatically detect received AMI or B8ZS coded signals to identify mis-configuration problems quickly.

- **DS0 Analysis**

Verify voice quality or analyze signaling bits by dropping the voice channel from DS1 to OC-12 access points.

- **Fractional T1 Testing**

Provide verification of leased contiguous and non-contiguous channels. In addition, single ended turnup can be assisted with far-end ESF PRMs.



The T-BERD 310's extensive DS1 measurements enable you to qualify and troubleshoot digital circuits.

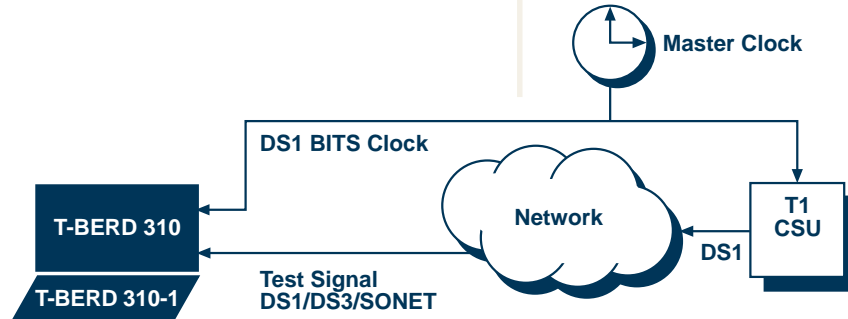

BITS Timing Analysis

Isolate sources of timing impairments in asynchronous or synchronous networks. Timing slips can be measured from DS1 tributaries in SONET or DS3 signals, as well as an external DS1. In addition, ESF synchronization messages are decoded to provide quick insight into the quality level of the BITS clock source.

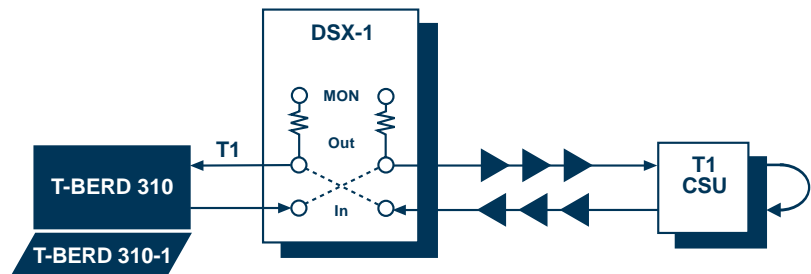

DS1 BERT

Detects common problems using a wide variety of standardized test patterns. Line code mismatch is found using All Zeros stress patterns. Level problems are highlighted with All Ones patterns. LUP patterns stress maximum ones density requirements to verify preamplification, equalization, and ALBO circuitry. Repeater timing recovery and M12 circuitry are also prequalified.

Specialized software programs, such as TTC's **Distributed Test Manager™ (DTM)**, **Remote Test Manager® (RTM)**, and **LabVIEW** from National Instruments Corporation™, go beyond remote control to expand the T-BERD 310's capabilities as a distributed test instrument.

DTM and RTM

DTM is a Windows-based software program that emulates the T-BERD 310 front panel in real time, allowing you to remotely control the T-BERD 310 (or other TTC test instruments) from your PC, or access it from a remote site. DTM enables centrally located technicians to perform comprehensive tests at remote locations. DTM also enables you to cut and paste test results into spreadsheets or other Windows applications.

RTM is a specialized software package that provides a graphical user interface of the T-BERD 310 front panel on a variety of platforms, including UNIX. RTM enables you to control multiple, remotely located T-BERD 310s from centrally located workstations. An extensive array of script files enables you to perform predefined sets of commands.



DTM and RTM extend the range of your T-BERD 310 and network maintenance personnel.

LabVIEW

LabVIEW is a user-customized graphical programming language available from National Instruments Corporation, which allows you greater flexibility in developing automated test routines. The T-BERD 310 software includes a driver that connects a T-BERD 310 to a wide variety of workstations, including Macintosh™, Sun®, HP®-UX, and IBM® or compatibles. LabVIEW provides programmable data acquisition, data analysis, and customized data presentation.

Additional Remote Options

In addition, you can use the field-upgradeable **Internal Modem Option** to dial up your T-BERD 310 and test your network from any remote location. Other remote access options include the **TA 3000 T3 Test Access System**, which connects TTC test equipment to any T3 line in the network, and **NetAnalyst Test Management Software**, a client/server, GUI-based software package that remotely accesses and tests the network at DS3/DS1/DS0 rates.

TTC Customer Care

TTC Customer Care starts with a three-year warranty on all mainframes¹ and includes repair and calibration capabilities worldwide. TTC also offers extended warranty options, as well as service/calibration plans to meet your unique needs. To complement our instruments and systems, TTC's Technical Assistance Center engineers offer expert consultation on any technical problem from 8 a.m. to 8 p.m. Monday through Friday, EST (**1-800-638-2049** or **1-301-353-1550**). And to support your changing testing applications and technologies, TTC provides practical, hands-on training that can be tailored to your specific needs.

¹See product manual for exclusions.

Specifications

Mainframe

Dimensions and Weight

Standard Chassis:

Overall Dimensions (with cover):

6.5 x 14 x 16 in.
(16.5 x 35.6 x 40.6 cm)

Weight (with cover):

22.6 lbs. (10.2 kg)

Extended Chassis (310-11 Option):

Overall Dimensions (with cover):

6.5 x 14 x 18.7 in.
(16.5 x 35.6 x 47.5 cm)

Weight (with cover):

24.2 lbs. (11 kg)

Environment

Temperature Range:

Operating:

0° to 45° C (32° to 113° F)

Storage:

-40° to 70° C (-40° to 158° F)

Shock and Vibration:

Meets or exceeds IEEE-743

Power Requirements

Power supply provides automatic detection for either 115 VAC or 220 VAC, 90 to 264 VAC from 47 to 63 Hz.

Fuse:

5A, 250V, Slo-Blo, 5x20 mm
(Little Fuse #218005 or equivalent)

Compliances and Specifications

ISO-9001 Registered

NRTL Approved to Underwriters Laboratories (UL)

Specifications

CSA Certified

FCC Part 15 Approved

DTM

T-BERD 310 Requirements

T-BERD 310 Software:

Rev. F or greater (basic T-BERD 310 interface)
Rev. G or greater (T-BERD 310-S user interface)

Workstation Requirements

Windows Operating System:

Microsoft® Windows 3.1 or greater

Personal Computer:

IBM-compatible PC
4 MB RAM

VGA or SVGA monitor (16 color recommended)

Modem Support:

Hayes-compatible modem (AT command set)
1200 baud minimum
9600 baud maximum

LabVIEW

T-BERD 310 Requirements

310-6 IEEE-488 Option

Workstation Requirements

Refer to the current National Instruments Corporation's *Instrumentation Reference and Catalogue*

Product Information

<i>Model No.</i>	<i>Description</i>
310	T-BERD Communications Analyzer (CLEI Code: SNTQAA63AA; CPR Code: 674296)
310-S	SONET/ATM User Interface (CLEI Code: SNTQAB93AA; CPR Code: 099604)
310-6	IEEE-488 Option (CLEI Code: SNTQABD3AA; CPR Code: 674303)
310-11	Three-Slot Expansion Option (CLEI Code: SNTQAB13AA; CPR Code: 674617)



U.S. Headquarters

Germantown, Maryland, USA

U.S. Offices

Atlanta, GA; Chicago, IL; Dallas, TX; Denver, CO;
East Rutherford, NJ; Los Angeles, CA;
Roanoke, VA; San Jose, CA

Worldwide Offices

Australia, Benelux, Canada, China, France,
Germany, Hong Kong, United Kingdom



TTC Products Are
Year 2000 Compliant



*Behind Successful Networks
You'll Find TTC*

20400 Observation Drive, Germantown, Maryland 20876
Tel. (800) 638-2049 • (301) 353-1550 (MD)
FAX (301) 353-0234 • www.ttc.com