

Acterna MTS 5100^e/5200^e Family of Field Optical Testers

5071 WDM Module



Features:

- Maintenance of C-band (1525-1570nm) with up to 12,5 Ghz channel spacing
- High wavelength accuracy (+/-0.02nm typical)
- No moving parts
- Enables OTDR and WDM testing in a single unit
- Up to 16 hours of operation
- Optional built-in printer (with MTS 5200^e)
- Comprehensive user interface with one button testing
- Automatic channel detection and measurement

The 5071 WDM plug-in module for the MTS 5100^e/5200^e family is a cost-effective solution for DWDM network maintenance in the C-band (1525-1570nm).

Comprehensive DWDM test

The 5071 WDM module tests all the parameters necessary for maintenance of the DWDM network, including channel wavelength, frequency, channel spacing, power and optical signal to noise ratio (OSNR).

Fast Acquisition and Analysis of DWDM Data

« One button testing » means that 5071 WDM module performs all data acquisition and analysis with a single

key-stroke. Parameters are presented over the full spectrum in wavelength and tabular formats, with a handy zoom function for more detailed analysis.

Efficient Testing of High Fiber Counts

To speed multiple fiber testing, 5071 WDM module features a macro function which can be user-programmed for automatic, successive measurement and analysis of large quantities of fibers.

All the test modules in the MTS 5100^e/5200^e range allow « multi-tasking » for continued data acquisition while test parameters are set-up or results are printed.

Advanced Modularity for the Field

The MTS 5100^e and 5200^e are the ideal platforms for outside plant applications.

Equipped with the 5071 WDM module, the MTS^e is the perfect tool to maintain DWDM networks. Optimized for field use (lightweight with 3.5 kg, up to 16 hours of operation and with no moving parts), it provides all test parameters to analyze the quality of a DWDM network of up to 12,5 Ghz channel spacing.

The WDM module is a new member of the family of MTS^e modules, which include the essential tools for installation and maintenance of fiber optic links : OTDR, loss test set, Visual Fault Locator, talk set.

Switching between functions takes only seconds, enabling the user to concentrate on measurement or results, rather than on instrument configuration. The MTS^e platform is the only unit able to measure fiber optic parameters and WDM parameters within seconds, without the need to swap modules.

Ready for Comprehensive Measurements and Statistical Analysis

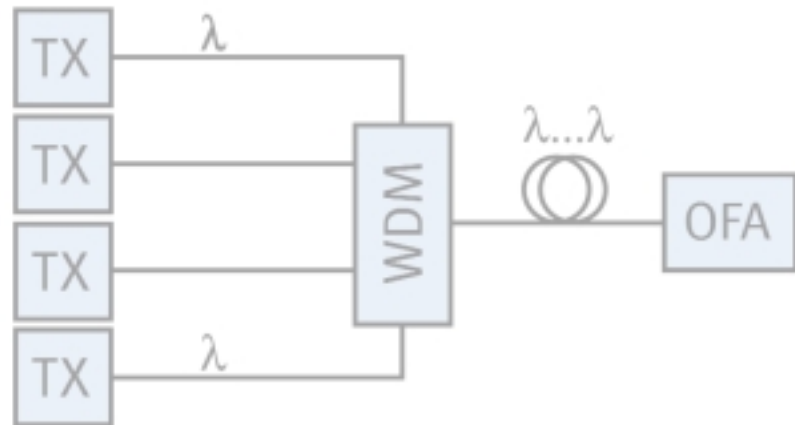

Configurable user interface

The intuitive interface of the 5071 WDM module is highly user-configurable. Measurement units (nm or THz), SNR measurement set-up (left, right, left and right or custom) and grid (ITU or manual) are user-specified, and channels can be sorted by number, wavelength, power level or OSNR.

Comprehensive measurements

In addition to the main DWDM parameters which are measured automatically at the touch of a button, the 5071 WDM module can be used to compare total or partial optical power, level, wavelength, gain tilt and gain slope between two points. An innovative overlay function makes it easy to compare stored waveforms.

Statistical Analysis

The 5071 WDM module can be used for statistical analysis of the results of long-term monitoring. User-defined limits identify potential problems, for effective preventative maintenance of the network.

File Management

The 5071 WDM module has a comprehensive file management system, which allows successive files to be named and stored automatically, semi-automatically or manually.



Comprehensive set-up screen

Automatic Maintenance Testing

During maintenance operation of a DWDM network, it is essential to have accurate knowledge of the optical spectrum, primarily the individual channel power and wavelengths, at critical points along the optical link : end terminals, optical amplifiers, add/drop nodes, cross connects and any other locations. Measuring the performance enables the operator to identify degradation or failure.

Complete Channel Analysis

The MTSE automatically provides all the necessary parameters to maintain a DWDM network. By pressing a single key, the MTSE performs an acquisition followed immediately by an analysis of the existing channels. This enables the user to rapidly detect if a channel is lower in power or missing, or if the entire network has been degraded.



Results screen with statistics on wavelength values

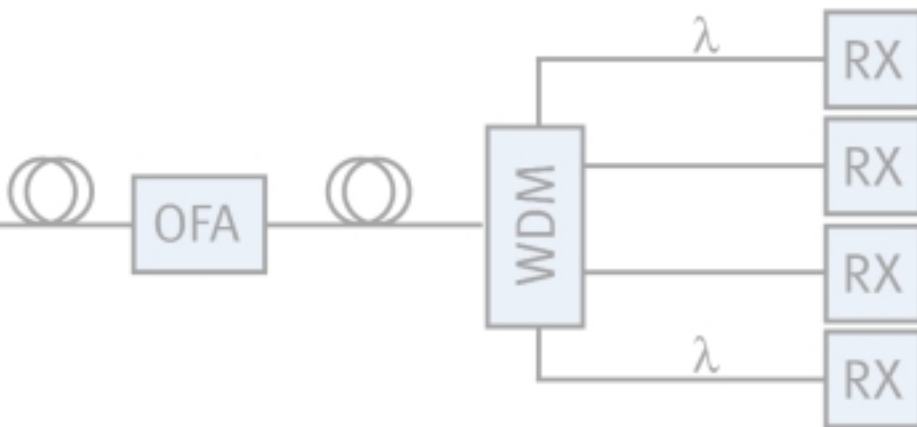

Measurement parameters are presented over the full spectrum in a waveform, as well as in a tabular display. For easy analysis, a simple 'click' on the table brings the relevant waveform centre screen, with a zoom function available for more detailed analysis. The MTSE automatically provides the following measurements for each channel:

- Number
- Wavelength
- Spacing
- Power level
- SNR
- Ratio between channel power level and composite power level

Composite power is also displayed, and slope gain and tilt gain are provided to indicate the quality of the amplified system.



5071 WDM Module for C-band

Product information

5071 WDM Module Specifications

The MTS 5100^e base unit is delivered as standard with an 8" LCD screen, RS-232C and Centronics interfaces, one AC/DC adapter, one battery, and a user manual. The MTS 5200^e is delivered with the same equipment as the MTS 5100^e but with two additional batteries. Both the MTS 5100^e and the MTS 5200^e can accept up to two field-interchangeable modules.

	Wavelength parameters
Range	1525 to 1570 nm
Display resolution	1 μ m
Accuracy	+/- 35 pm (+/- 20 pm typical)
Minimum channel spacing	0.2 nm (12.5 GHz)
	Power level parameters
Display range	-90 to +30 dBm
Display resolution	0.01 dB
Accuracy	+/-0.5 dB (-30 dBm, 1550 nm)
Linearity (typical)	+/- 0.1 dB (-40 to +10 dBm)
OSNR (0.1nm bandwidth)	33/29 (0.8 / 0.4 nm)
Polarization dependance	+/-0.2 dB
Optical return loss	>35 dB
Sweep time	1 s (real time)

Base Unit Options

5000/Hdisk	Hard Disk Drive
5000/FD	Floppy Disk Drive
5000/Pas	High Definition VGA Color Display : Passive Matrix
5000/Col	High Definition VGA Color Display : Active Matrix
5000/ETH	Ethernet option
5200/IEEE	IEEE Interface for MTS 5200 ^e
5200/PR	Built in Thermal Printer for MTS 5200 ^e (with 12 rolls)
5200/VGA	Display Output for MTS 5200 ^e (With 5000/Col Only)

WDM Module

5071 WDM	C-band WDM Module
----------	-------------------

Application Software

9557	Labview Driver for MTSE ^e Platform
9552	WinWDM software for PC post-processing

Main Accessories

5000/Keyb	External Keyboard
5001	Additional Rechargeable Battery
5002	External Battery Charger
5004	Soft Carrying Case
5005	Hard Transit Case
5006	Cigarette Lighter Power Adapter
5008	Additional Batch of 12 Paper Rolls for MTS 5200 ^e Printer

WDM Module Connectors

Standard single mode FC/PC, SC, ST, DIN, E2000, EC, VFO, FC/APC, SC/APC, DIN/HRL, E2000HRL.
Standard multimode FC/PC, SC, ST, DIN, PFO

UNI/PC/NAD : Universal single mode or multimode PC connectors with use of adapters

UNI/FC/AD, UNI/SC/AD, UNI/ST/AD or UNI/DIN/AD

UNI/APC/NAD : Universal single mode APC connectors with use of adapters UNI/FC/AD,

UNI/SC/AD, UNI/ST/AD or UNI/DIN/AD

For more information on test adapters,
cables and fiber optic couplers,
see the separate datasheet:
Acterna Fiber Optic Test Adapters and Cables

(FOST-MT02 E 07/01 AE)

Specifications subject to change without notice
Copyright 2001 Acterna, LLC. All rights reserved.

Acterna Global Headquarters

20400 Observation Drive
Germantown
Maryland 20876-4023
USA
Toll Free 1 800 638 2049 or
Tel +1 301 353 1550
Fax +1 301 444 8468
www.acterna.com

Regional Sales Headquarters

North America

20400 Observation Drive
Germantown,
Maryland 20876-4023
USA
Toll Free 1 800 638 2049
Tel +1 301 353 1550
Fax +1 301 444 8468

Latin America

Av. Eng. Luis Carlos Berrini,
936 8/9. Andar
04571-000 Sao Paulo, SP
Brazil
Tel +55 11 5503 3800
Fax +55 11 5505 1598

Asia/Pacific

42 Clarendon Street
PO Box 141
South Melbourne, Victoria 3205
Australia
Tel +61 3 9690 6700
Fax +61 3 9690 6750

Western Europe

Arbachtalstrasse 6
72800 Eningen u.A.
Germany
Tel +49 7121 86 2222
Fax +49 7121 86 1222

Eastern Europe, Middle East & Africa

Elisabethstrasse 36
PO Box 13
2500 Baden
Austria
Tel +43 2252 85 521 0
Fax +43 2252 80 727

1st Neopalimovskiy Per. 15/7
(4th floor)
119121 Moscow
Russia
Tel +7 095 248 2508
Fax +7 095 248 4189

Acterna is present in more than
80 countries. To find your local
sales office go to www.acterna.com

